

distinte di taglio cutting sizes

atlantis
serie wood 72 TT

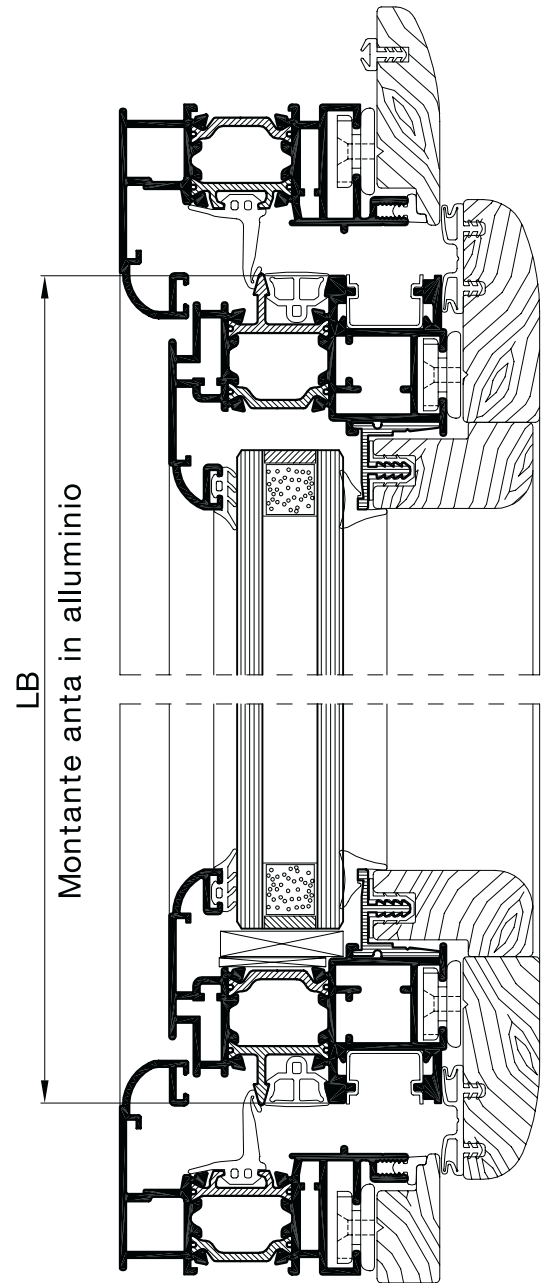

TO.MA. S.p.a.
ESTRUSIONE ALLUMINIO

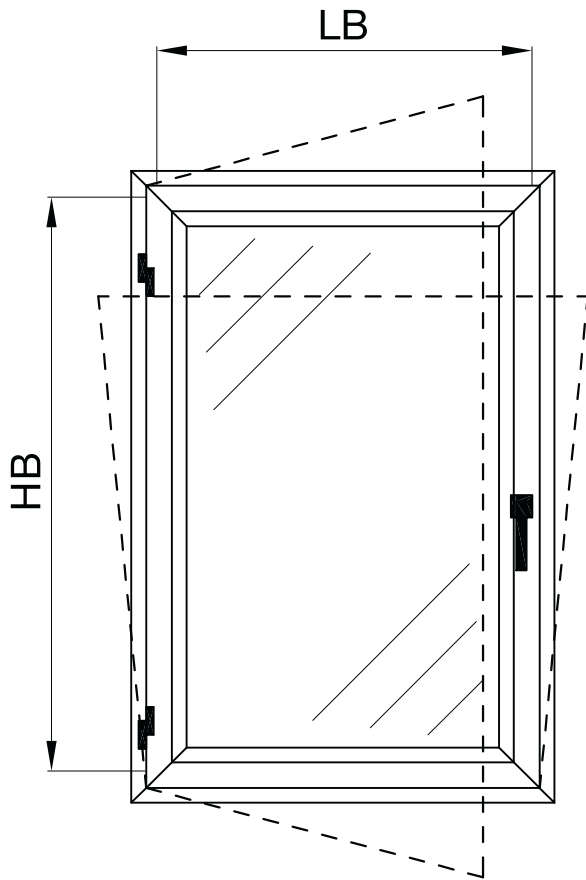

LB = MISURA LARGHEZZA CANALINA FERRAMENTA
HB = MISURA ALTEZZA CANALINA FERRAMENTA

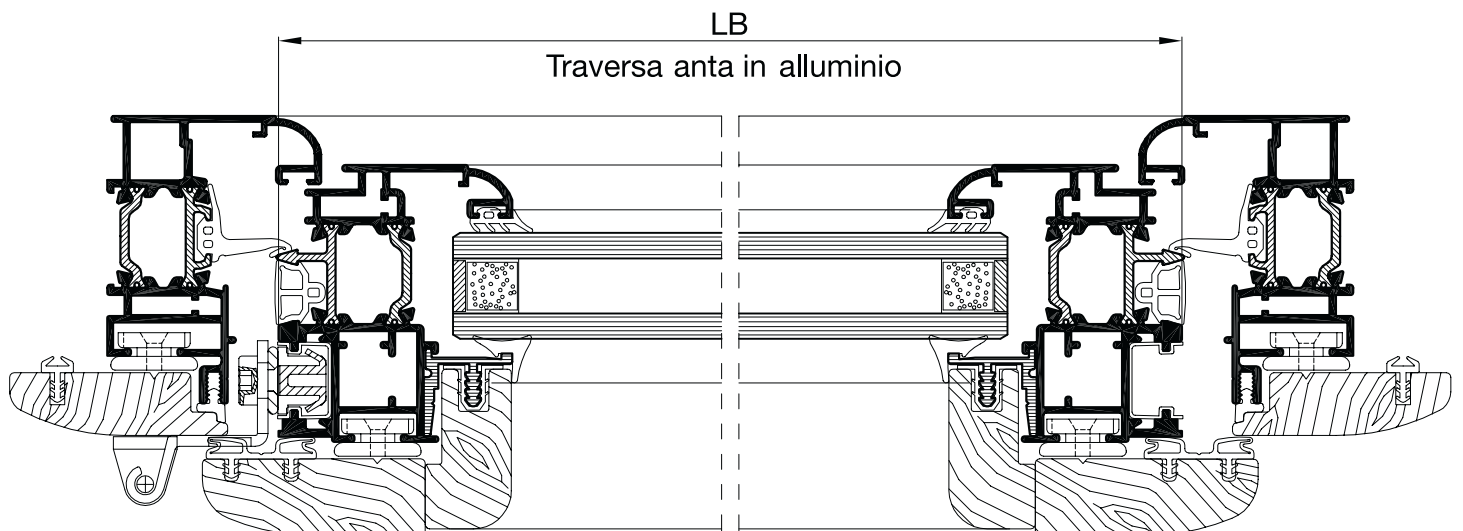

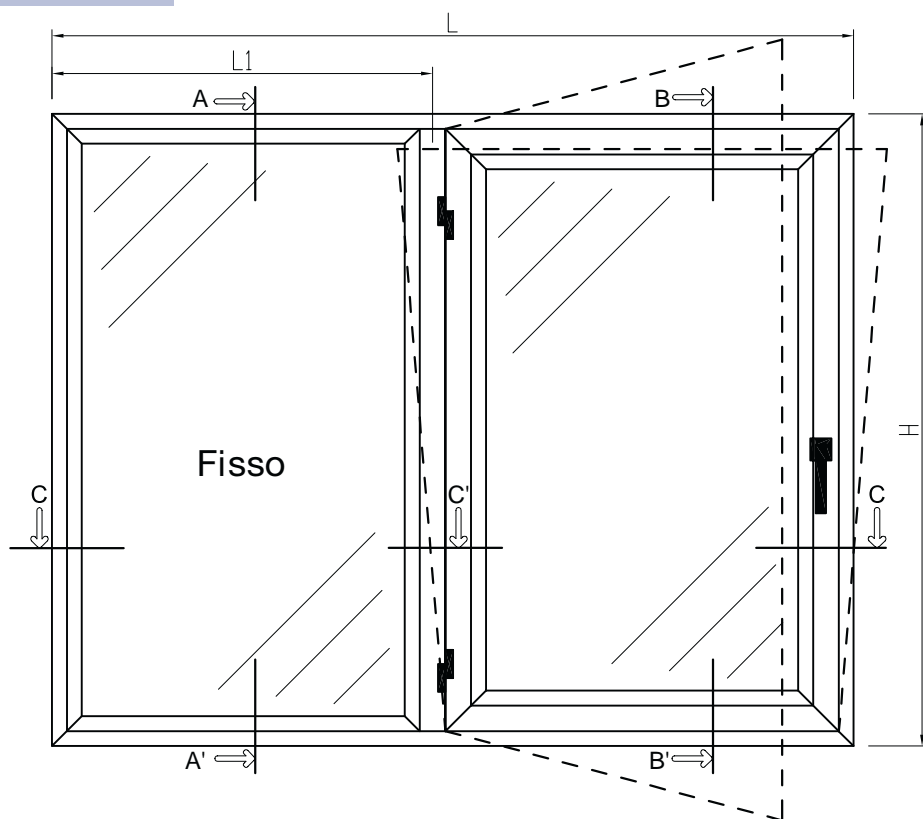

CALCOLO PESO PROFILI		TOTALE KG
Profili Orizz.	Kg/ml $6,3 \times L$	
Profili Vert.	Kg/ml $8,7 \times H$	
TOTALE		

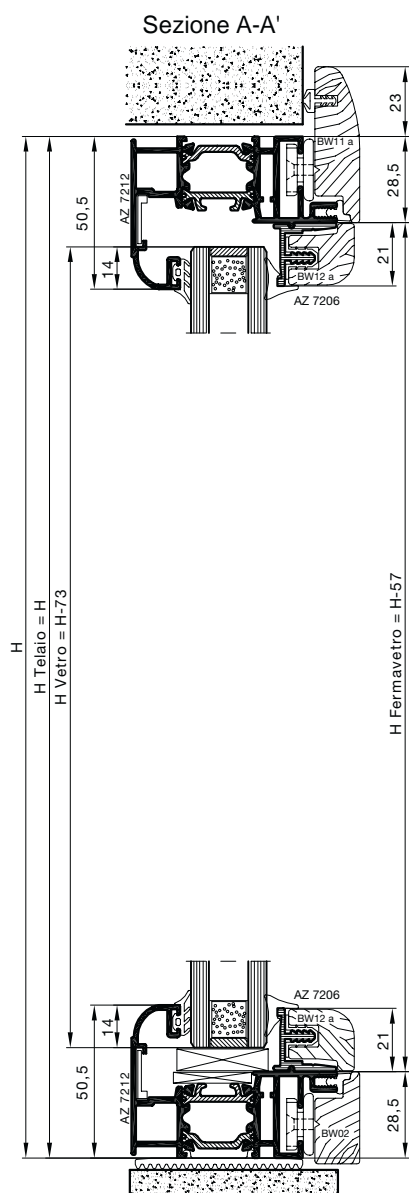

DISTINTA TAGLIO VETRI			
Posizione	l	h	Q.tà
	L - L1 - 159,8	H - 164	1
Fisso	L - L1 - 69,5	H - 164	1

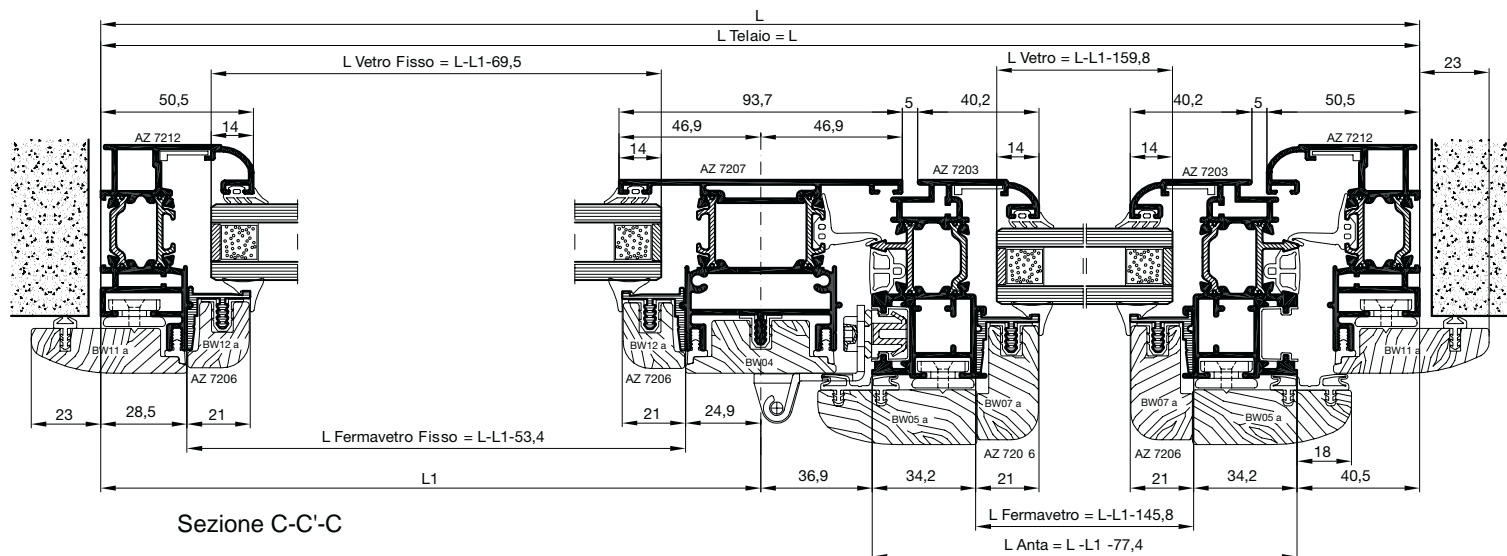

Sezione B-B' vedi finestra ad una o due ante

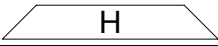

DISTINTA TAGLIO PROFILI

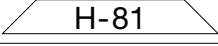
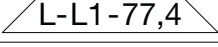
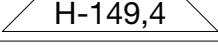
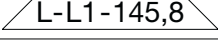
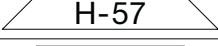
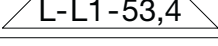
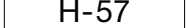
Nr. Pezzi	CODICI	DESCRIZIONE	TAGLIO
2	AZ 7212	MONTANTE TELAIO	 H
2	AZ 7212	TRAVERSO TELAIO	 L
2	AZ 7203	MONTANTE ANTA	 H-81
2	AZ 7203	TRAVERSO ANTA	 L-L1-77,4
2	AZ 7206	FERMAVETRO MONT.	 H-149,4
2	AZ 7206	FERMAVETRO TRAV.	 L-L1-145,8
2	AZ 7206	FERMAVETRO FISSO MONT.	 H-57
2	AZ 7206	FERMAVETRO FISSO TRAV.	 L-L1-53,4
2	AZ 7207	FASCIA MONT.	 H-57

DISTINTA TAGLIO LEGNI

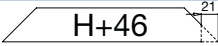
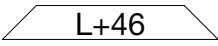
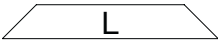
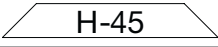
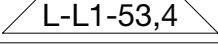
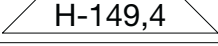
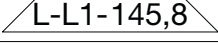
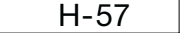



Nr. Pezzi	CODICI	DESCRIZIONE	TAGLIO
2	BW 11 a	TELAIO MONTANTE	 H+46 ²¹
1	BW 11 a	TELAIO TRAVERSO SUP.	 L+46
1	BW 02	TELAIO TRAVERSO INF.	 L
2	BW 05 a	ANTA MONTANTE	 H-45
2	BW 05 a	ANTA TRAVERSO	 L-L1-41,4
2	BW 12 a	FERMAVETRO MONT. FISSO	 H-57
2	BW 12 a	FERMAVETRO TRAV. FISSO	 L-L1-53,4
2	BW 07 a	FERMAVETRO MONT. ANTA	 H-149,4
2	BW 07 a	FERMAVETRO TRAV. ANTA	 L-L1-145,8
1	BW 04	"T" FASCIA MONTANTE FISSO	 H-57

ACCESSORI

ART.	DESCRIZIONE	N° P.zzi
Ra 1704	SQUADRETTA DI ALLINEAMENTO	8
Ra 2306	SQUADRETTA PER ANTA E TELAIO	8
Ra 1709	SQUADRETTA PER ANTA E TELAIO	8
Ra 1033	CAPPETTA DI DRENAGGIO	2
Ra 2303	REGOLATORE A MURO PER TELAIO PICCOLO	9-12 <small>(secondo dimensioni)</small>
Ra 2301	BLOCCHETTI DI UNIONE LEGNO ALLUMINIO PICCOLO	1 ogni 200mm

E' ESCLUSA LA FERRAMENTA DI MOVIMENTAZIONE

GUARNIZIONI

	ART.	DESCRIZIONE	N° P.zzi
	Rg 345	G. INTERNA VETRO	2L + 4H
	Rg 311	G. ESTERNA VETRO	2L + 4H
	Rg 322	G. CENTRALE DI TENUTA	(2L-2L1)+2H
	Rg 319	G. DI FINITURA	(2L-2L1)+2H
	Rg 344	G. A MURO	1L + 2H
	Rg 335	G. BATTUTA INTERNA	(2L-2L1)+2H
	Ra 1403	ANGOLO VULCANIZATO	4
	Rg 334	G. DI FISSAGGIO FERMAVETRO	2L + 5H
	Rg 333	CANALINA ISOLAMENTO FERRAMENTA	(2L-2L1)+2H
	Rg 336	G. ISOLAMENTO ALLUMINIO LEGNO	2L + 4H
	Rg 338	G. ISOLAMENTO SOGLIA	1L

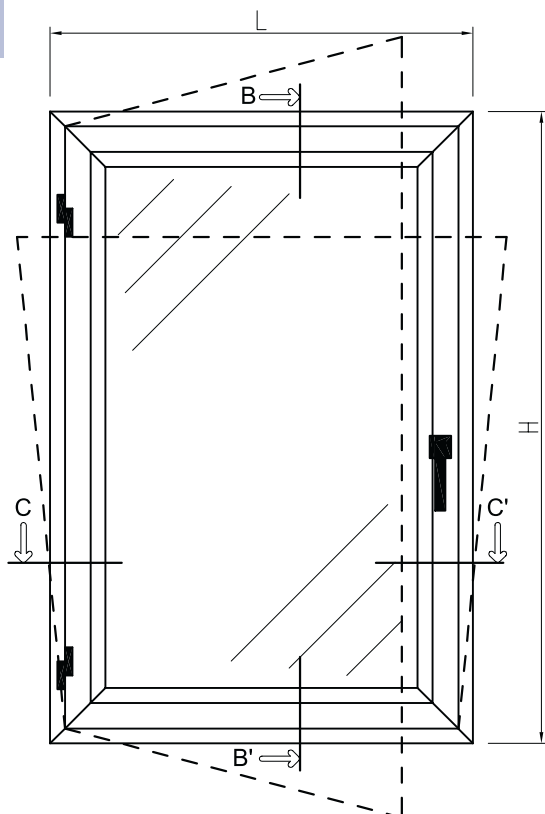

Sezione B-B'

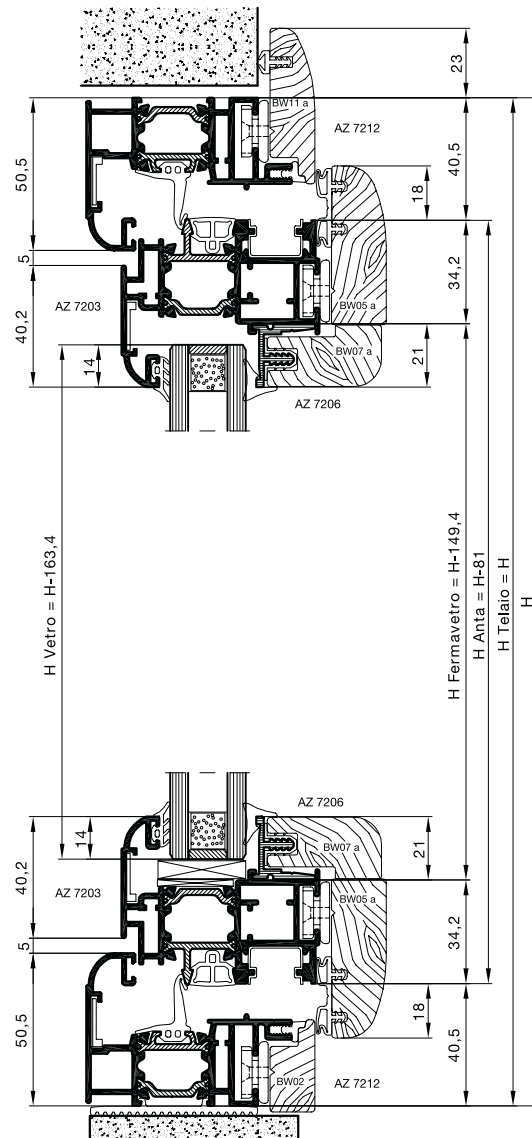

CALCOLO PESO PROFILI		TOTALE KG
Profili Orizz.	Kg/ml $6,3 \times L$	
Profili Vert.	Kg/ml $6,3 \times H$	
TOTALE		

DISTINTA TAGLIO VETRI			
Posizione	l	h	Q.tà
	L - 163,4	H - 163,4	1

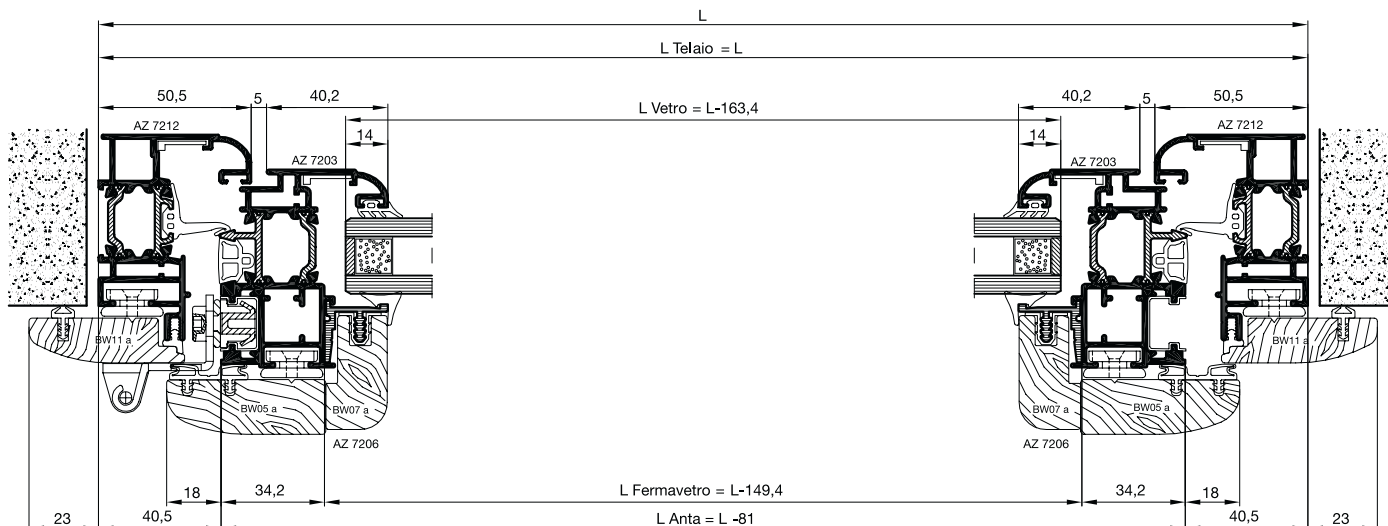

Sezione C-C'

DISTINTA TAGLIO PROFILI

Nr. Pezzi	CODICI	DESCRIZIONE	TAGLIO
2	AZ 7212	MONTANTE TELAIO	H
2	AZ 7212	TRAVERSO TELAIO	L
2	AZ 7203	MONTANTE ANTA	H-81
2	AZ 7203	TRAVERSO ANTA	L-81
2	AZ 7206	FERMAVETRO MONTANTE	H-149,4
2	AZ 7206	FERMAVETRO TRAVERSO	L-149,4

DISTINTA TAGLIO LEGNI

Nr. Pezzi	CODICI	DESCRIZIONE	TAGLIO
1	BW 11 a	TELAIO TRAVERSO SUP.	L+46
1	BW 02	TELAIO TRAVERSO INF.	L
2	BW 11 a	TELAIO MONTANTE	H+46
2	BW 05 a	ANTA MONTANTE	H-45
2	BW 05 a	ANTA TRAVERSO	L-45
2	BW 07 a	FERMAVETRO MONTANTE	H-149,4
2	BW 07 a	FERMAVETRO TRAVERSO	L-149,4

ACCESSORI

ART.	DESCRIZIONE	N° P.zzi
Ra 1704	SQUADRETTA DI ALLINEAMENTO	8
Ra 2306	SQUADRETTA PER ANTA E TELAIO	8
Ra 1709	SQUADRETTA PER ANTA E TELAIO	8
Ra 1033	CAPPETTA DI DRENAGGIO	2
Ra 2301	BLOCCHETTI DI UNIONE LEGNO ALLUMINIO	1 ogni 200mm
Ra 2303	REGOLATORE A MURO PER TELAIO PICCOLO	6-10 <small>(secondo dimensioni)</small>

E' ESCLUSA LA FERRAMENTA DI MOVIMENTAZIONE

GUARNIZIONI

	ART.	DESCRIZIONE	N° P.zzi
	Rg 345	G. INTERNA VETRO	2L + 2H
	Rg 311	G. ESTERNA VETRO	2L + 2H
	Rg 322	G. CENTRALE DI TENUTA	2L + 2H
	Rg 319	G. DI FINITURA	2L + 2H
	Rg 344	G. A MURO	1L + 2H
	Rg 335	G. BATTUTA INTERNA	2L + 2H
	Ra 1403	ANGOLO VULCANIZATO	4
	Rg 334	G. DI FISSAGGIO FERMAVETRO	2L + 2H
	Rg 333	CANALINA ISOLAMENTO FERRAMENTA	2L + 2H
	Rg 336	G. ISOLAMENTO ALLUMINIO LEGNO	2L + 2H
	Rg 338	G. ISOLAMENTO SOGLIA	1L

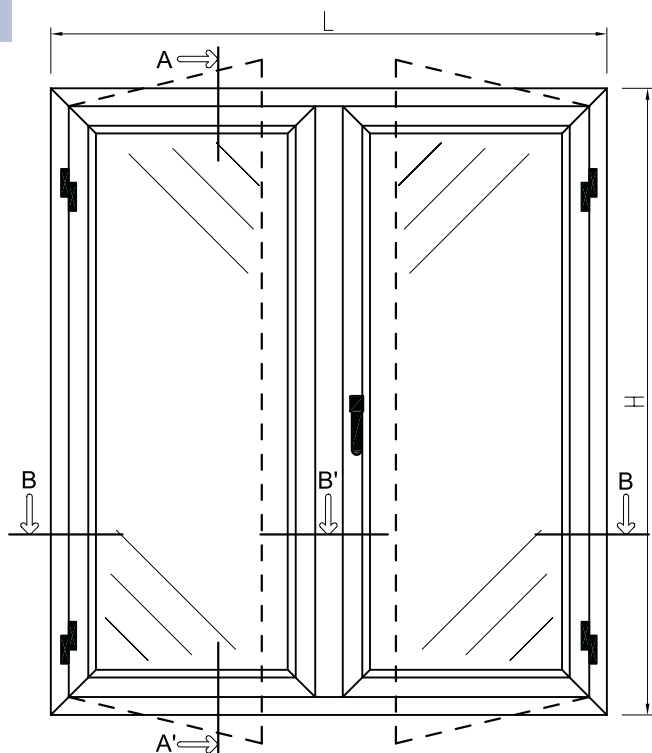

Sezione A-A'

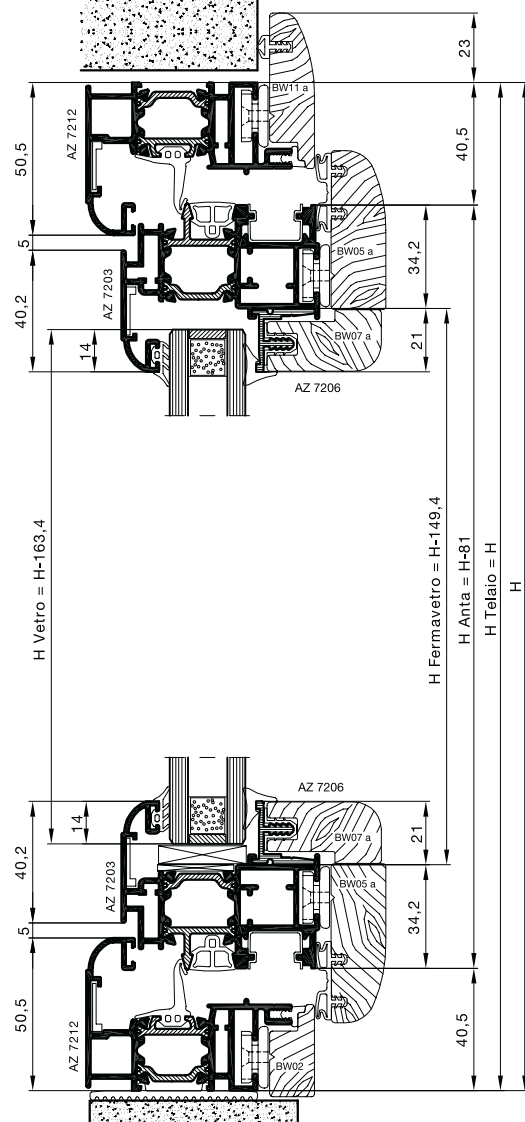

CALCOLO PESO PROFILI		TOTALE KG
Profili Orizz.	Kg/ml $6,3 \times L$	
Profili Vert.	Kg/ml $11,3 \times H$	
TOTALE		

DISTINTA TAGLIO VETRI			
Posizione	l	h	Q.tà
	L/2-143,4	H - 163,4	2

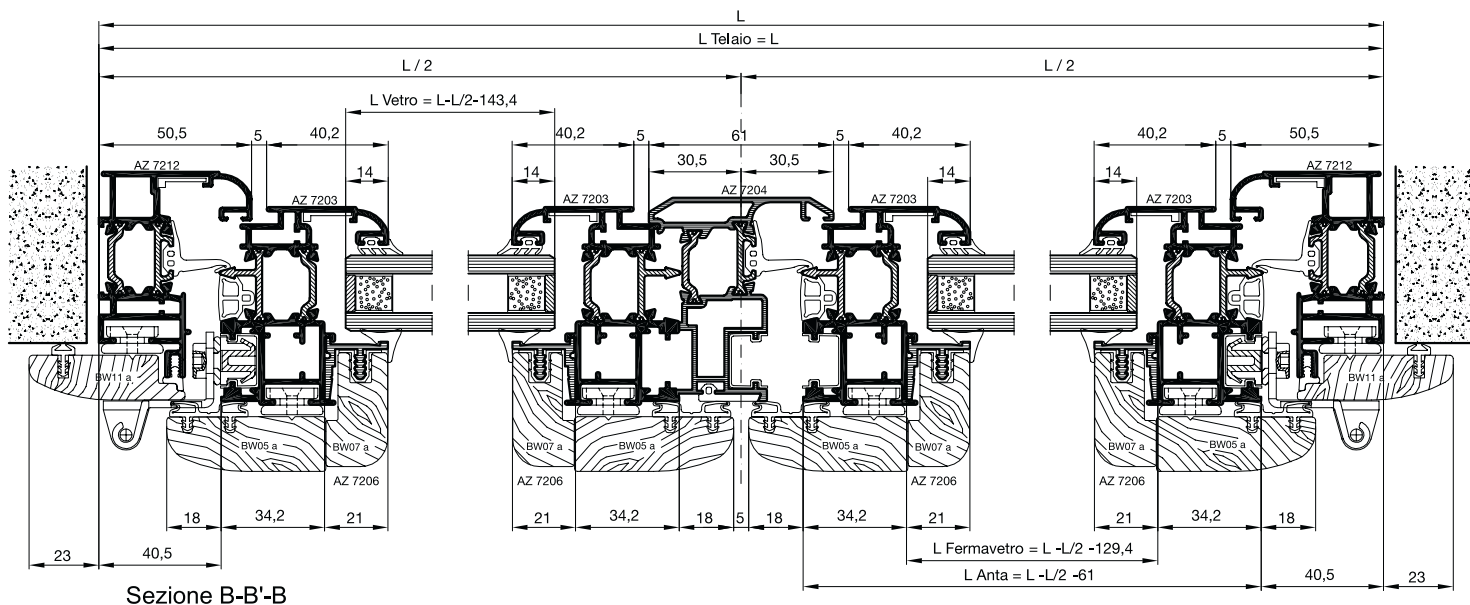

Sezione B-B'-B

DISTINTA TAGLIO PROFILI

Nr. Pezzi	CODICI	DESCRIZIONE	TAGLIO
2	AZ 7212	MONTANTE TELAIO	 H
2	AZ 7212	TRAVERSO TELAIO	 L
4	AZ 7203	MONTANTE ANTA	 H-81
4	AZ 7203	TRAVERSO ANTA	 L-L/2-61
4	AZ 7206	FERMAVETRO MONT.	 H-149,4
4	AZ 7206	FERMAVETRO TRAV.	 L-L/2-129,4
1	AZ 7204	RISCONTRO CENTRALE	 H-111

DISTINTA TAGLIO LEGNI

Nr. Pezzi	CODICI	DESCRIZIONE	TAGLIO
2	BW 11 a	TELAIO MONTANTE	 H+46 
1	BW 11 a	TELAIO TRAVERSO SUP.	 L+46
1	BW 02	TELAIO TRAVERSO INF.	 L
4	BW 05 a	ANTA MONTANTE	 H-45
4	BW 05 a	ANTA TRAVERSO	 L-L/2-25
4	BW 07 a	FERMAVETRO MONTANTE	 H-149,4
4	BW 07 a	FERMAVETRO TRAVERSO	 L-L/2-129,4

ACCESSORI

ART.	DESCRIZIONE	N° P.zzi
Ra 1704	SQUADRETTA DI ALLINEAMENTO	12
Ra 2306	SQUADRETTA PER ANTA E TELAIO	12
Ra 1709	SQUADRETTA PER ANTA E TELAIO	12
Ra 1033	CAPPETTA DI DRENAGGIO	2
Ra 2301	BLOCCHETTI DI UNIONE LEGNO ALLUMINIO	1 ogni 200mm
Ra 2303	REGOLATORE A MURO PER TELAIO PICCOLO	9-12 (secondo dimensioni)

E' ESCLUSA LA FERRAMENTA DI MOVIMENTAZIONE

GUARNIZIONI

	ART.	DESCRIZIONE	N° P.zzi
	Rg 345	G. INTERNA VETRO	2L + 4H
	Rg 311	G. ESTERNA VETRO	2L + 4H
	Rg 322	G. CENTRALE DI TENUTA	2L + 3H
	Rg 319	G. DI FINITURA	2L + 3H
	Rg 344	G. A MURO	1L + 2H
	Rg 335	G. BATTUTA INTERNA	2L + 4H
	Ra 1403	ANGOLO VULCANIZATO	4
	Rg 334	G. DI FISSAGGIO FERMAVETRO	2L + 4H
	Rg 333	CANALINA ISOLAMENTO FERRAMENTA	2L + 4H
	Rg 336	G. ISOLAMENTO ALLUMINIO LEGNO	2L + 2H
	Rg 338	G. ISOLAMENTO SOGLIA	1L

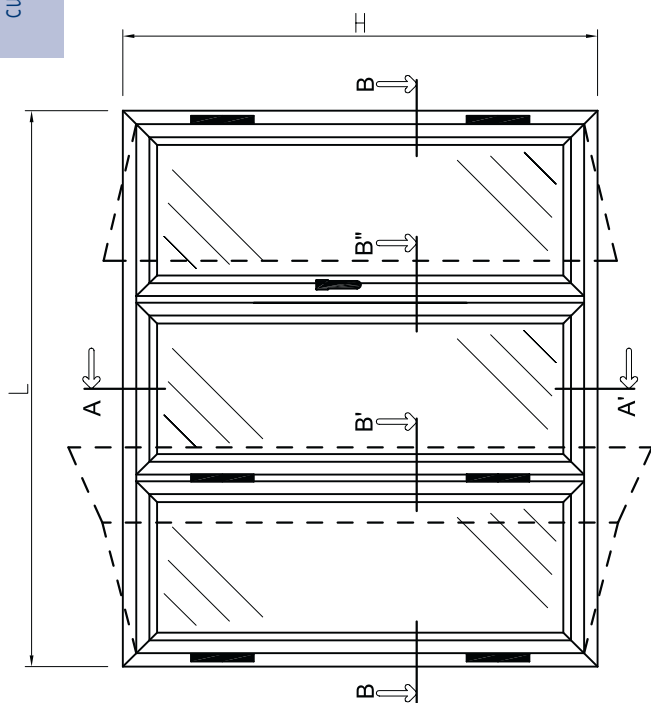

CALCOLO PESO PROFILI		TOTALE
		KG
Profili Orizz.	Kg/ml 6,3 x L	
Profili Vert.	Kg/ml 16,3 x H	
TOTALE		

DISTINTA TAGLIO VETRI			
Posizione	l	h	Q.tà
	L/3-136,7	H-163,4	3

Sezione A-A'

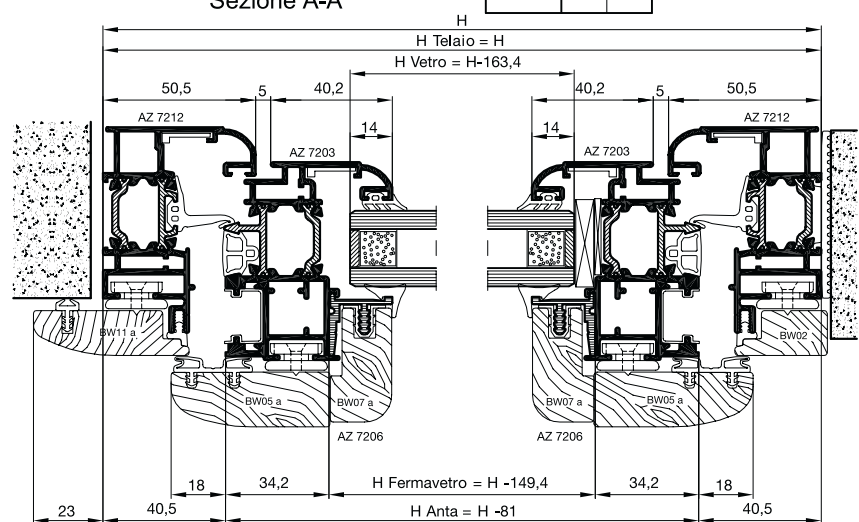

Sezione B-B'-B''-B

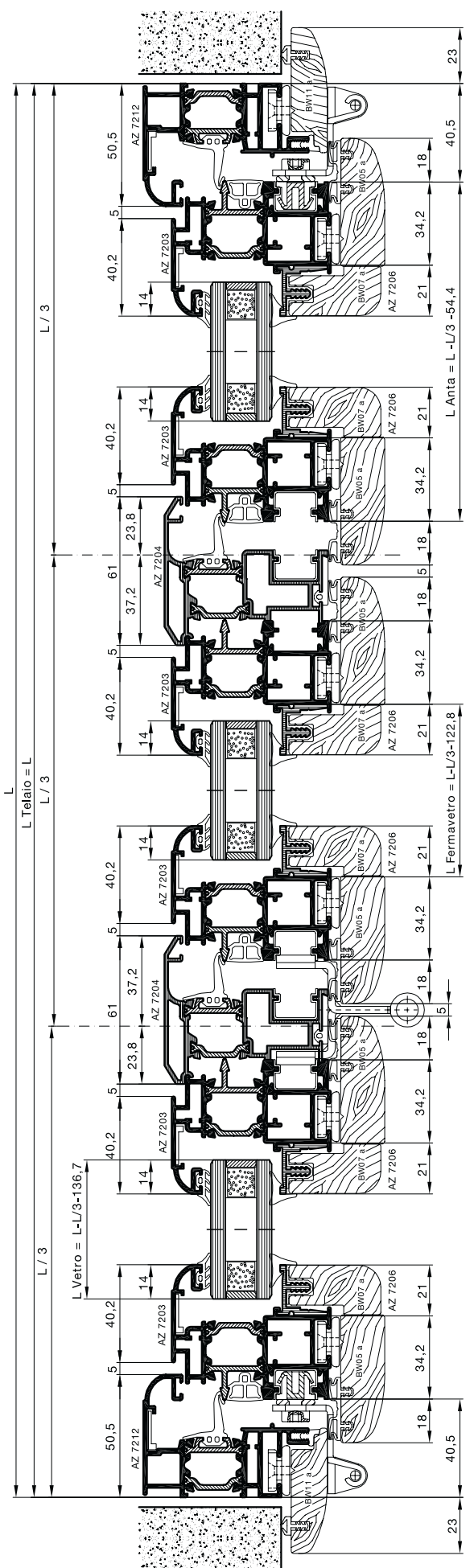

DISTINTA TAGLIO PROFILI

Nr. Pezzi	CODICI	DESCRIZIONE	TAGLIO
2	AZ 7212	MONTANTE TELAIO	 H
2	AZ 7212	TRAVERSO TELAIO	 L
6	AZ 7203	MONTANTE ANTA	 H-81
6	AZ 7203	TRAVERSO ANTA	 L-L/3-54,4
6	AZ 7206	FERMAVETRO MONT.	 H-149,4
6	AZ 7206	FERMAVETRO TRAV.	 L-L/3-122,8
2	AZ 7204	RISCONTRO CENTRALE	 H-111

DISTINTA TAGLIO LEGNI

Nr. Pezzi	CODICI	DESCRIZIONE	TAGLIO
2	BW 11 a	TELAIO MONTANTE	 H+46 
1	BW 11 a	TELAIO TRAVERSO SUP.	 L+46
1	BW 02	TELAIO TRAVERSO INF.	 L
6	BW 05 a	ANTA MONTANTE	 H-45
6	BW 05 a	ANTA TRAVERSO	 L-L/3-18,4
6	BW 07 a	FERMAVETRO MONTANTE	 H-149,4
6	BW 07 a	FERMAVETRO TRAVERSO	 L-L/3-122,8

ACCESSORI

ART.	DESCRIZIONE	N° P.zzi
Ra 1704	SQUADRETTA DI ALLINEAMENTO	16
Ra 2306	SQUADRETTA PER ANTA E TELAIO	16
Ra 1709	SQUADRETTA PER ANTA E TELAIO	16
Ra 1033	CAPPETTA DI DRENAGGIO	3
Ra 2301	BLOCCHETTI DI UNIONE LEGNO ALLUMINIO	1 ogni 200mm
Ra 2303	REGOLATORE A MURO PER TELAIO PICCOLO	9-12 <small>(secondo dimensioni)</small>

E' ESCLUSA LA FERRAMENTA DI MOVIMENTAZIONE

GUARNIZIONI

	ART.	DESCRIZIONE	N° P.zzi
	Rg 345	G. INTERNA VETRO	2L + 6H
	Rg 311	G. ESTERNA VETRO	2L + 6H
	Rg 322	G. CENTRALE DI TENUTA	2L + 4H
	Rg 319	G. DI FINITURA	2L + 4H
	Rg 344	G. A MURO	1L + 2H
	Rg 335	G. BATTUTA INTERNA	2L + 6H
	Ra 1403	ANGOLO VULCANIZATO	4
	Rg 334	G. DI FISSAGGIO FERMAVETRO	2L + 6H
	Rg 333	CANALINA ISOLAMENTO FERRAMENTA	2L + 7H
	Rg 336	G. ISOLAMENTO ALLUMINIO LEGNO	2L + 2H
	Rg 338	G. ISOLAMENTO SOGLIA	1L

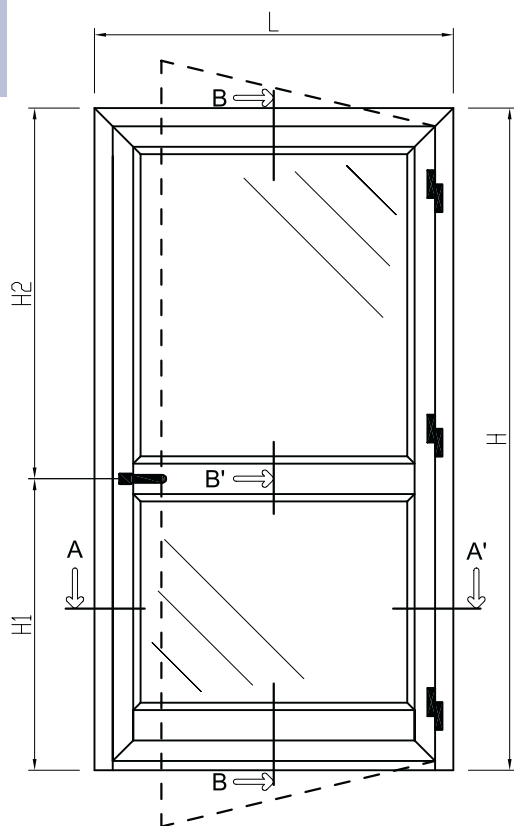

CALCOLO PESO PROFILI		TOTALE
	Kg/ml	KG
Profili Orizz.	6,8 x L	
Profili Vert.	10,4 x H	
TOTALE		

DISTINTA TAGLIO VETRI			
Posizione	l	h	Q.tà
Superiore	L - 190	H-H1-127,9	1
Inferiore	L - 190	H-H2-172,7	1

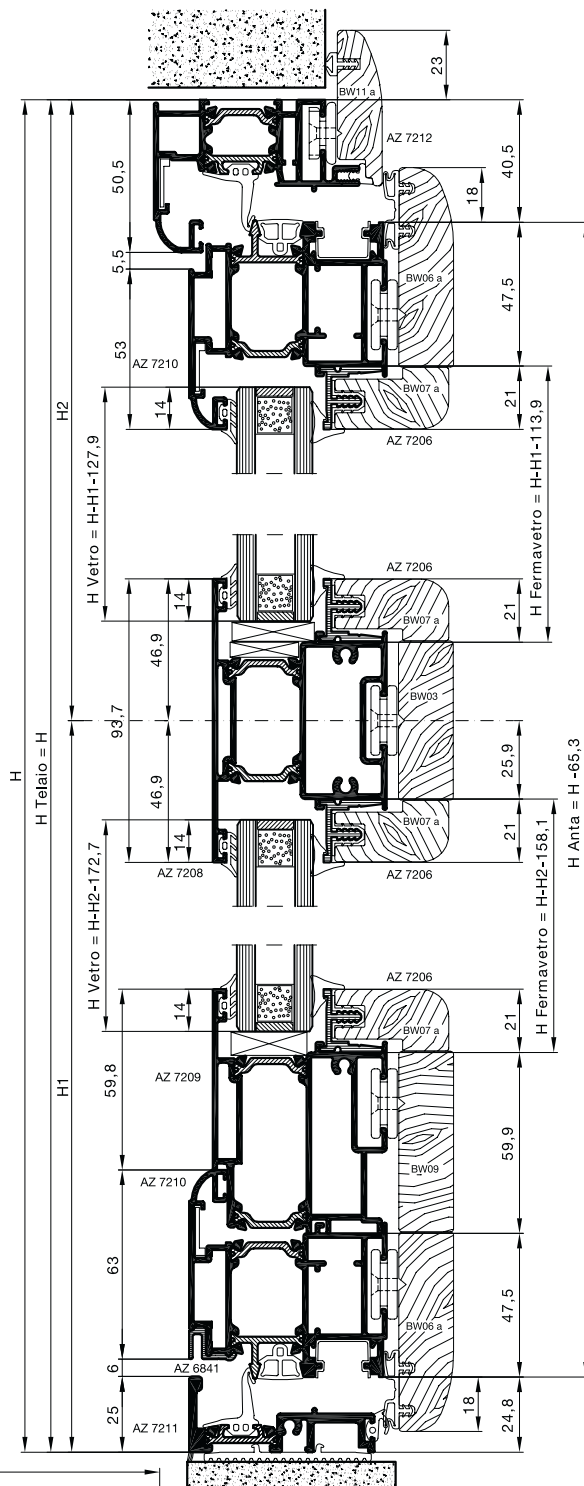

Sezione B-B

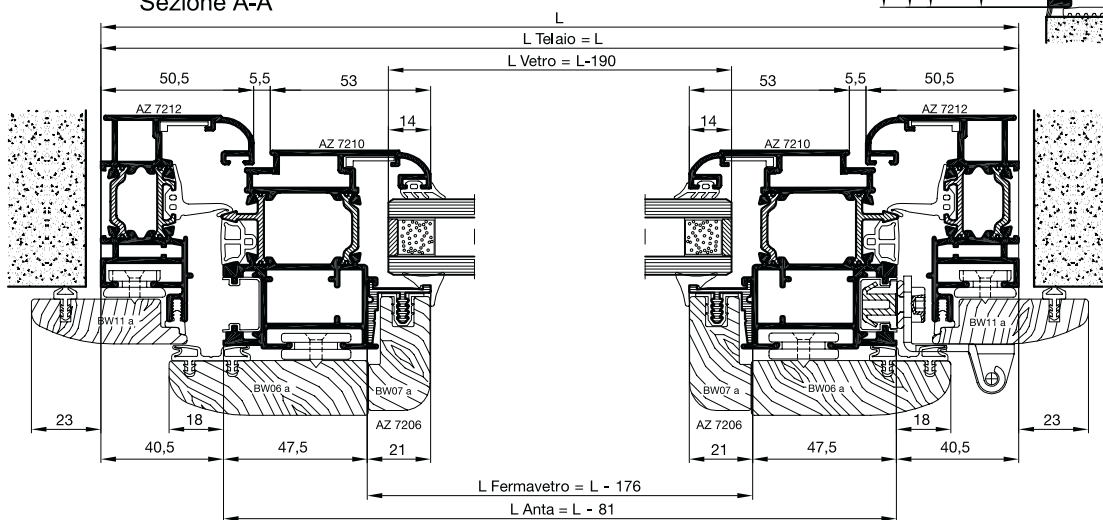

Sezione A-A'

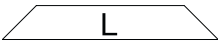
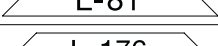
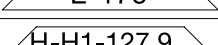
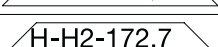

DISTINTA TAGLIO PROFILI

Nr. Pezzi	CODICI	DESCRIZIONE	TAGLIO
1	AZ 7212	TRAVERSO TELAIO SUP.	
1	AZ 7211	TRAVERSO TELAIO INF.	
2	AZ 7212	MONTANTE TELAIO	
2	AZ 7210	MONTANTE ANTA	
2	AZ 7210	TRAVERSO ANTA	
4	AZ 7206	FERMAVETRO TRAV.	
2	AZ 7206	FERMAVETRO MONT. SUP.	
2	AZ 7206	FERMAVETRO MONT. INF.	
1	AZ 7208	FASCIA	
1	AZ 7209	ZOCCOLO RIPORTATO	
1	AZ 6841	COPRIFUGA	

DISTINTA TAGLIO LEGNI

Nr. Pezzi	CODICI	DESCRIZIONE	TAGLIO
2	BW 11 a	TELAIO MONTANTE	
1	BW 11 a	TELAIO TRAVERSO SUP.	
2	BW 06 a	ANTA MONTANTE	
2	BW 06 a	ANTA TRAVERSO	
2	BW 07 a	FERMAVETRO MONTANTE SUP.	
2	BW 07 a	FERMAVETRO MONTANTE INF.	
4	BW 07 a	FERMAVETRO TRAVERSO CEN.	
1	BW 03	FASCIA	
1	BW 09	ZOCCOLO RIPORTATO	

ACCESSORI

ART.	DESCRIZIONE	N° P.zzi
Ra 1704	SQUADRETTA DI ALLINEAMENTO	6
Ra 2306	SQUADRETTA PER TELAIO	2
Ra 1709	SQUADRETTA PER TELAIO	2
Ra 2006	SQUADRETTA PER ANTA	4
Ra 2307	SQUADRETTA PER ANTA	4
Ra 1033	CAPPETTA DI DRENAGGIO	2
Ra 2301	BLOCCHETTI DI UNIONE LEGNO ALLUMINIO	1 ogni 200mm
Ra 2302	BLOCCHETTI DI UNIONE LEGNO ALLUMINIO GRANDE	1 ogni 200mm
Ra 2303	REGOLATORE A MURO PER TELAIO PICCOLO	6-10 <small>(seconda dimensioni)</small>

E' ESCLUSA LA FERRAMENTA DI MOVIMENTAZIONE

GUARNIZIONI

	ART.	DESCRIZIONE	N° P.zzi
	Rg 345	G. INTERNA VETRO	4L + 2H
	Rg 311	G. ESTERNA VETRO	4L + 2H
	Rg 322	G. CENTRALE DI TENUTA	2L + 2H
	Rg 319	G. DI FINITURA	2L + 2H
	Rg 344	G. A MURO	1L + 2H
	Rg 335	G. BATTUTA INTERNA	2L + 2H
	Ra 1403	ANGOLO VULCANIZATO	4
	Rg 334	G. DI FISSAGGIO FERMAVETRO	4L + 2H
	Rg 333	CANALINA ISOLAMENTO FERRAMENTA	2L + 2H
	Rg 336	G. ISODAMENT ALLUMINIO LEGNO	1L + 2H
	Rg 338	G. ISOLAMENTO SOGLIA	1L
	Rg 303	G. DI BATTUTA SOGLIA	1L

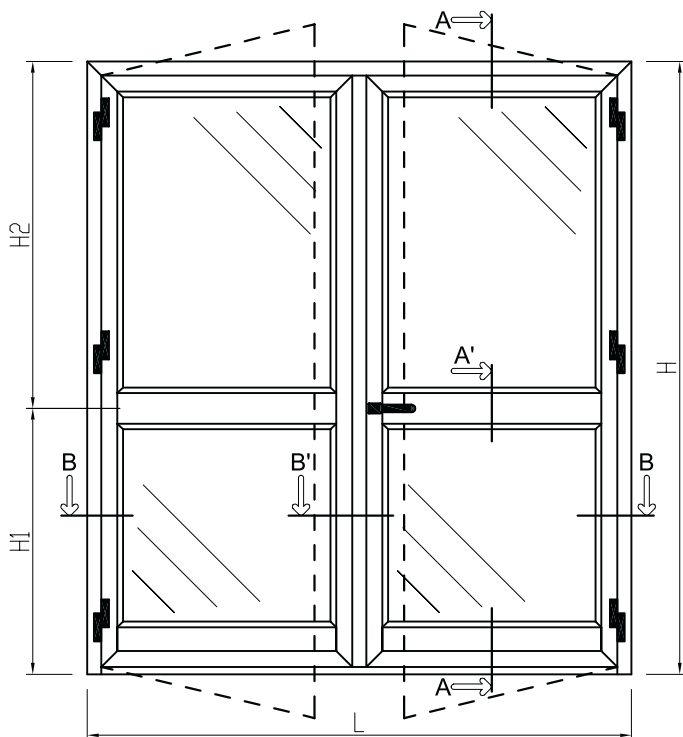

CALCOLO PESO PROFILI		TOTALE KG
Profili Orizz.	Kg/ml $10,4 \times L$	
Profili Vert.	Kg/ml $12,4 \times H$	
TOTALE		

DISTINTA TAGLIO VETRI			
Posizione	l	h	Q.tà
Superiore	$L-L/2-170$	$H-H1-127,9$	2
Inferiore	$L-L/2-170$	$H-H2-172,7$	2



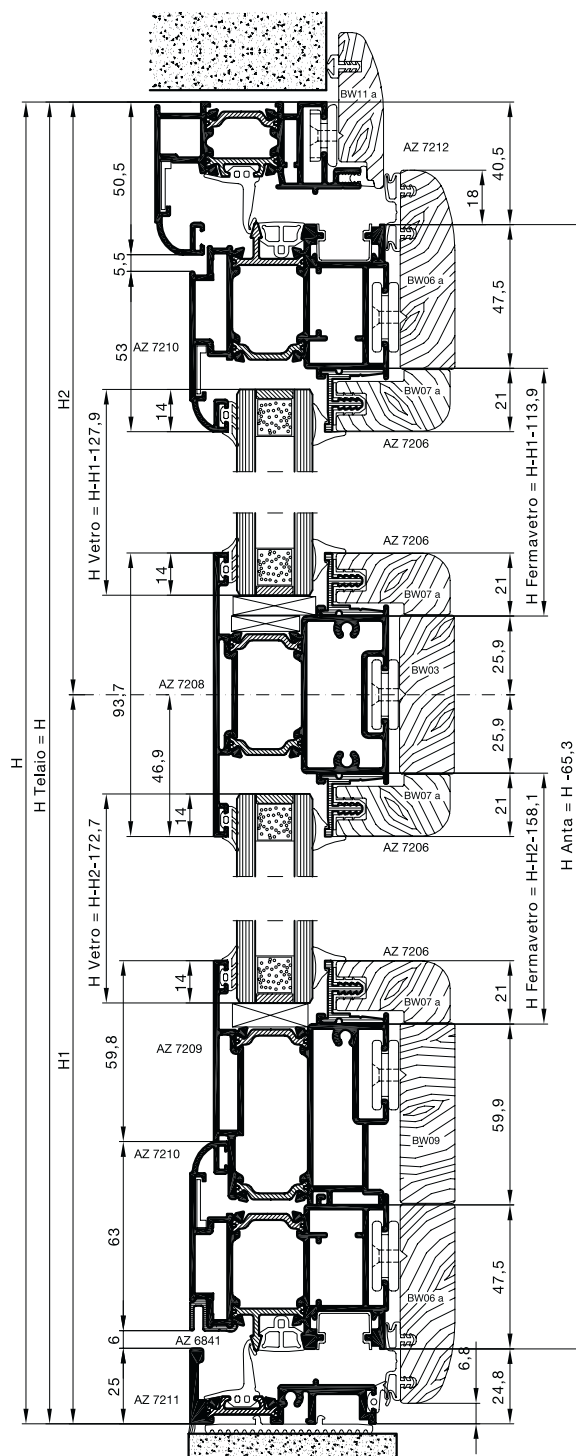

Sezione A-A'-A

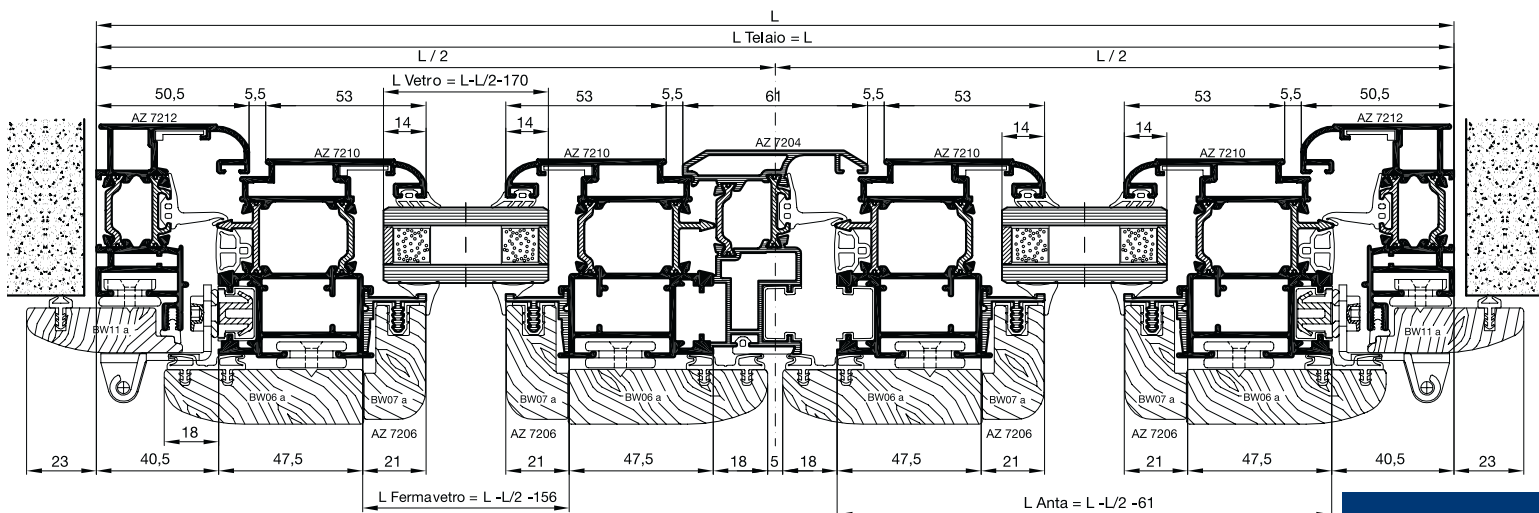

Sezione B-B'-B

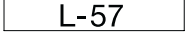

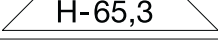
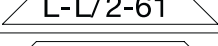
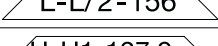
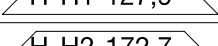
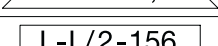
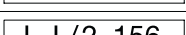
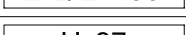
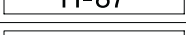
DISTINTA TAGLIO PROFILI

Nr. Pezzi	CODICI	DESCRIZIONE	TAGLIO
1	AZ 7212	TRAVERSO TELAIO SUP.	
1	AZ 7211	TRAVERSO TELAIO INF.	
2	AZ 7212	MONTANTE TELAIO	
4	AZ 7210	MONTANTE ANTA	
4	AZ 7210	TRAVERSO ANTA	
8	AZ 7206	FERMAVETRO TRAV.	
4	AZ 7206	FERMAVETRO MONT. SUP.	
4	AZ 7206	FERMAVETRO MONT. INF.	
2	AZ 7208	FASCIA	
2	AZ 7209	ZOCCOLO RIPORTATO	
1	AZ 7204	RISCONTRO CENTRALE	
2	AZ 6841	COPRIFUGA	

DISTINTA TAGLIO LEGNI

Nr. Pezzi	CODICI	DESCRIZIONE	TAGLIO
2	BW 11 a	TELAIO MONTANTE	
1	BW 11 a	TELAIO TRAVERSO SUP.	
4	BW 06 a	ANTA MONTANTE	
4	BW 06 a	ANTA TRAVERSO	
4	BW 07 a	FERMAVETRO MONTANTE SUP.	
4	BW 07 a	FERMAVETRO MONTANTE INF.	
8	BW 07 a	FERMAVETRO PER TRAVERSO	
2	BW 03	FASCIA	
2	BW 09	ZOCCOLO RIPORTATO	

ACCESSORI

ART.	DESCRIZIONE	N° P.zzi
Ra 1704	SQUADRETTA DI ALLINEAMENTO	10
Ra 2306	SQUADRETTA PER TELAIO	2
Ra 1709	SQUADRETTA PER TELAIO	2
Ra 2006	SQUADRETTA PER ANTA	8
Ra 2307	SQUADRETTA PER ANTA	8
Ra 1033	CAPPETTA DI DRENAGGIO	3
Ra 2301	BLOCCHETTI DI UNIONE LEGNO ALLUMINIO	1 ogni 200mm
Ra 2302	BLOCCHETTI DI UNIONE LEGNO ALLUMINIO GRANDE	1 ogni 200mm
Ra 2303	REGOLATORE A MURO PER TELAIO PICCOLO	9-12 (seconda dimensioni)

E' ESCLUSA LA FERRAMENTA DI MOVIMENTAZIONE

GUARNIZIONI

	ART.	DESCRIZIONE	N° P.zzi
	Rg 345	G. INTERNA VETRO	4L + 4H
	Rg 311	G. ESTERNA VETRO	4L + 4H
	Rg 322	G. CENTRALE DI TENUTA	2L + 3H
	Rg 319	G. DI FINITURA	2L + 3H
	Rg 344	G. A MURO	1L + 2H
	Rg 335	G. BATTUTA INTERNA	2L + 4H
	Ra 1403	ANGOLO VULCANIZATO	4
	Rg 334	G. DI FISSAGGIO FERMAVETRO	4L + 4H
	Rg 333	CANALINA ISOLAMENTO FERRAMENTA	2L + 4H
	Rg 336	G. ISOLAMENTO ALLUMINIO LEGNO	1L + 2H
	Rg 338	G. ISOLAMENTO SOGLIA	1L

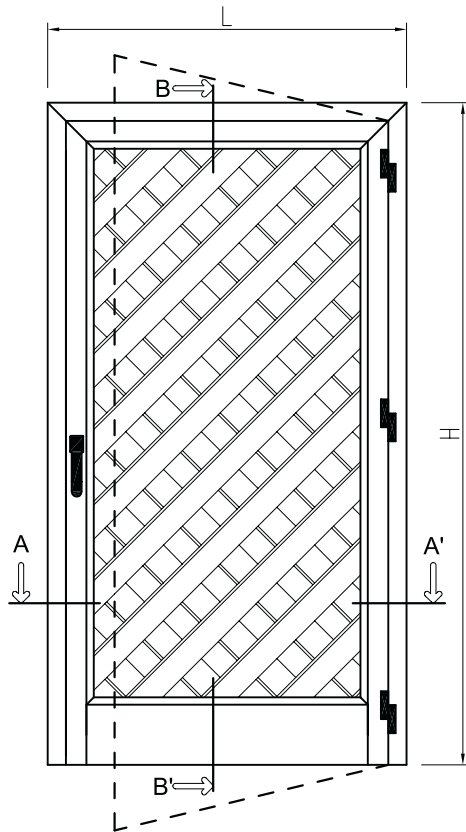

Sezione B-B'

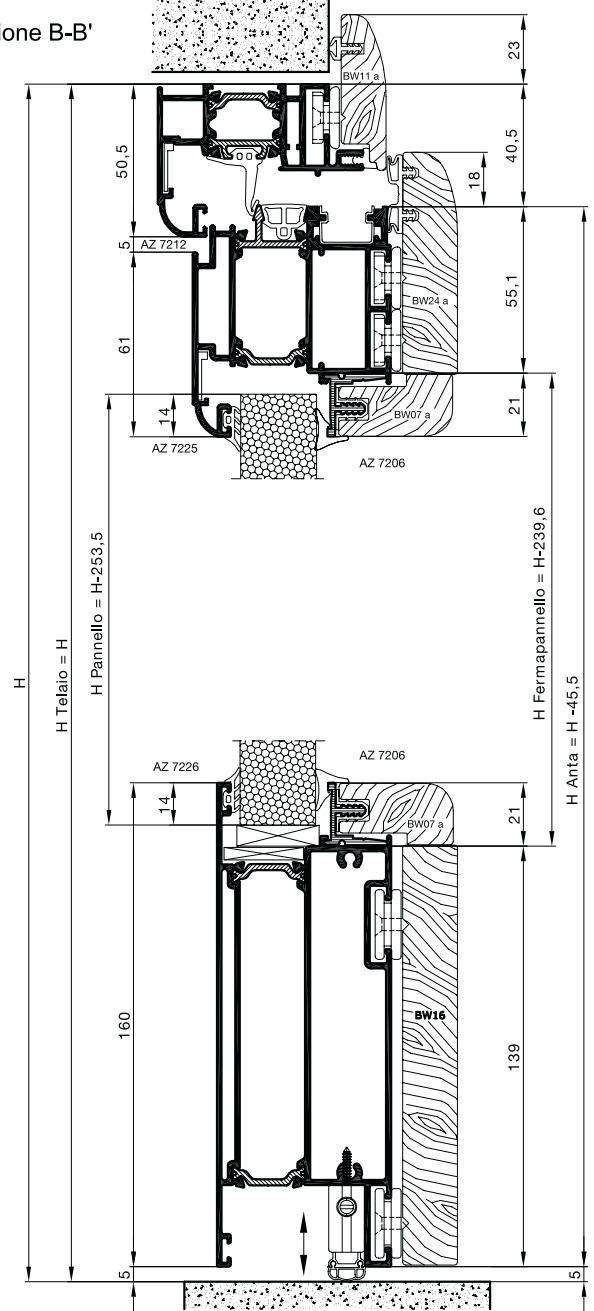

CALCOLO PESO PROFILI		TOTALE KG
Profili Orizz.	Kg/ml <u>7</u> x L	
Profili Vert.	Kg/ml <u>7</u> x H	
TOTALE		

DISTINTA TAGLIO PANNELLO			
Posizione	l	h	Q.tà
	L - 205	H - 253,5	1

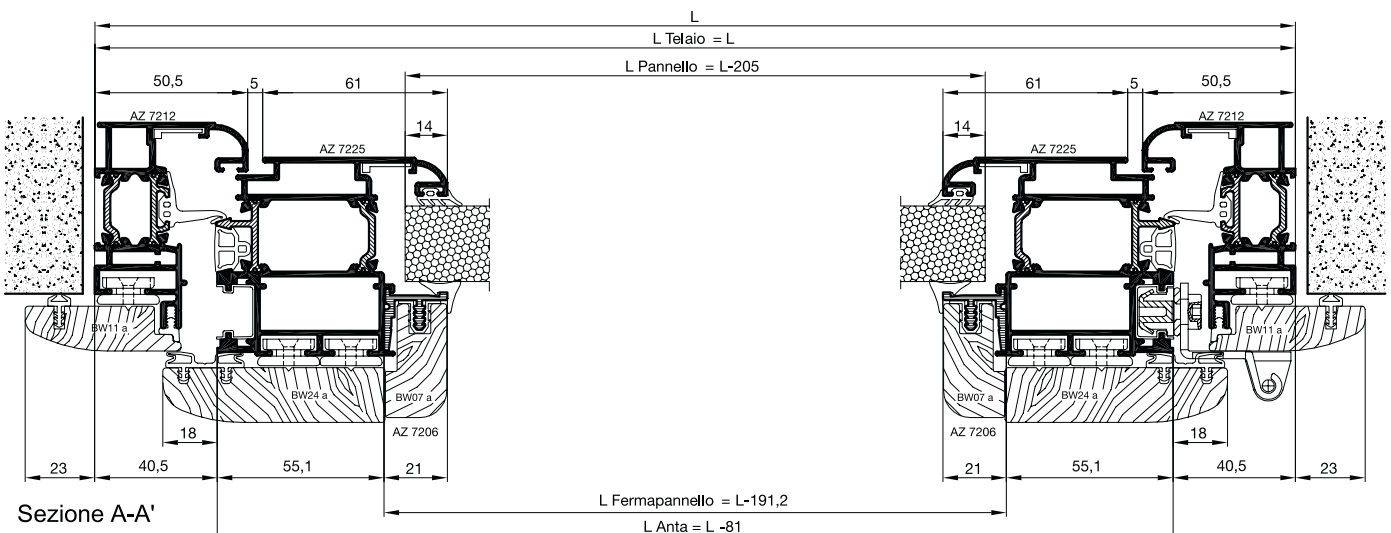

DISTINTA TAGLIO PROFILI			
Nr. Pezzi	CODICI	DESCRIZIONE	TAGLIO
2	AZ 7212	MONTANTE TELAIO	
1	AZ 7212	TRAVERSO TELAIO SUP.	
2	AZ 7225	MONTANTE ANTA	
1	AZ 7225	TRAVERSO ANTA SUP.	
2	AZ 7206	FERMAPANNELLO MONT.	
2	AZ 7206	FERMAPANNELLO TRAV.	
1	AZ 7226	ZOCCOLO	

DISTINTA TAGLIO LEGNI			
Nr. Pezzi	CODICI	DESCRIZIONE	TAGLIO
2	BW 11 a	TELAIO MONTANTE	
1	BW 11 a	TELAIO TRAVERO SUP.	
1	BW 16	ZOCCOLO	
2	BW 24 a	ANTA MONTANTE	
1	BW 24 a	ANTA TRAVERSO SUP.	
2	BW 07 a	FERMAPANNELLO MONT.	
2	BW 07 a	FERMAPANNELLO TRAV.	

ACCESSORI		
ART.	DESCRIZIONE	N° P.zzi
Ra 1704	SQUADRETTA DI ALLINEAMENTO	4
Ra 2306	SQUADRETTA PER TELAIO	2
Ra 1709	SQUADRETTA PER TELAIO	2
Ra 2305	SQUADRETTA PER ANTA	2
Ra 2309	SQUADRETTA PER ANTA	2
Ra 2301	BLOCCHETTI DI UNIONE LEGNO ALLUMINIO	1 ogni 200mm
Ra 2302	BLOCCHETTI DI UNIONE LEGNO ALLUMINIO GRANDE	1 ogni 200mm
Ra 2328	KIT DI TENUTA SOTTOZOCZOLO tipo 2	1
Ra 2303	REGOLATORE A MURO PER TELAIO PICCOLO	6-10 (secondo dimensioni)

E' ESCLUSA LA FERRAMENTA DI MOVIMENTAZIONE

GUARNIZIONI			
	ART.	DESCRIZIONE	N° P.zzi
	Rg 345	G. INTERNA VETRO	2L + 2H
	Rg 311	G. ESTERNA VETRO	2L + 2H
	Rg 322	G. CENTRALE DI TENUTA	1L + 2H
	Rg 319	G. DI FINITURA	1L + 2H
	Rg 344	G. A MURO	1L + 2H
	Rg 335	G. BATTUTA INTERNA	1L + 2H
	Ra 1403	ANGOLO VULCANIZATO	2
	Rg 334	G. DI FISSAGGIO FERMAVETRO	2L + 2H
	Rg 333	CANALINA ISOLAMENTO FERRAMENTA	1L + 2H
	Rg 336	G. ISOLAMENTO ALLUMINIO LEGNO	1L + 2H

DISTINTA TAGLIO PROFILI

Nr. Pezzi	CODICI	DESCRIZIONE	TAGLIO
2	AZ 7212	MONTANTE TELAIO	H
1	AZ 7212	TRAVERSO TELAIO SUP.	L
4	AZ 7225	MONTANTE ANTA	H-45,5
2	AZ 7225	TRAVERSO ANTA SUP.	L-L/2-61
4	AZ 7206	FERMAPANNELLO MONT.	H-239,6
4	AZ 7206	FERMAPANNELLO TRAV.	L-L/2-171,2
2	AZ 7226	ZOCCOLO	L-L/2-171,2
1	AZ 7204	RISCONTRO CENTRALE	H-60,5

DISTINTA TAGLIO LEGNI

Nr. Pezzi	CODICI	DESCRIZIONE	TAGLIO
2	BW 11 a	TELAIO MONTANTE	H+23
1	BW 11 a	TELAIO TRAVERSO SUP.	L+46
2	BW 16	ZOCCOLO	L-L/2-171,2
4	BW 24 a	ANTA MONTANTE	H-27,5
2	BW 24 a	ANTA TRAVERSO SUP.	L-L/2-25
4	BW 07 a	FERMAPANNELLO MONT.	H-239,6
4	BW 07 a	FERMAPANNELLO TRAV.	L-L/2-171,2

ACCESSORI

ART.	DESCRIZIONE	N° P.zzi
Ra 1704	SQUADRETTA DI ALLINEAMENTO	6
Ra 2306	SQUADRETTA PER TELAIO	2
Ra 1709	SQUADRETTA PER TELAIO	2
Ra 2305	SQUADRETTA PER ANTA	4
Ra 2309	SQUADRETTA PER ANTA	4
Ra 2301	BLOCCHETTI DI UNIONE LEGNO ALLUMINIO	1 ogni 200mm
Ra 2302	BLOCCHETTI DI UNIONE LEGNO ALLUMINIO GRANDE	1 ogni 200mm
Ra 2328	KIT DI TENUTA SOTTOZOCZOLO tipo 2	1
Ra 2303	REGOLATORE A MURO PER TELAIO PICCOLO	9-12 <small>(secondo dimensioni)</small>

E' ESCLUSA LA FERRAMENTA DI MOVIMENTAZIONE

GUARNIZIONI

	ART.	DESCRIZIONE	N° P.zzi
	Rg 345	G. INTERNA VETRO	2L + 4H
	Rg 311	G. ESTERNA VETRO	2L + 4H
	Rg 322	G. CENTRALE DI TENUTA	1L + 3H
	Rg 319	G. DI FINITURA	1L + 3H
	Rg 344	G. A MURO	1L + 2H
	Rg 335	G. BATTUTA INTERNA	1L + 4H
	Ra 1403	ANGOLO VULCANIZATO	2
	Rg 334	G. DI FISSAGGIO FERMAVETRO	2L + 4H
	Rg 333	CANALINA ISOLAMENTO FERRAMENTA	1L + 4H
	Rg 336	G. ISOLAMENTO ALLUMINIO LEGNO	1L + 2H

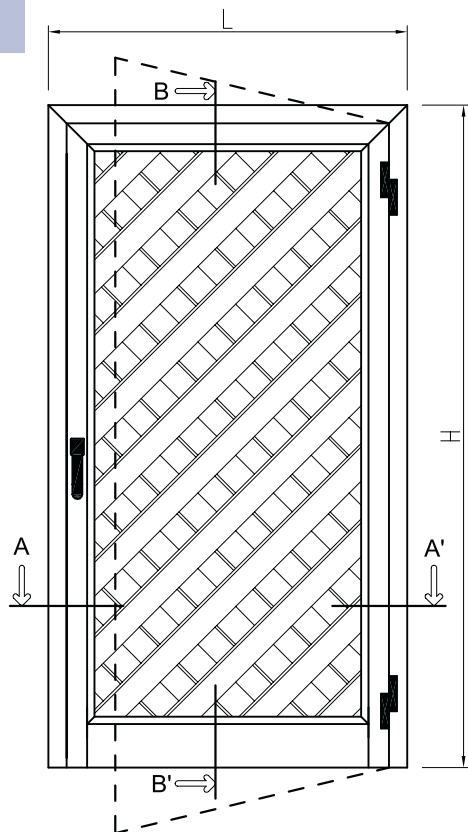





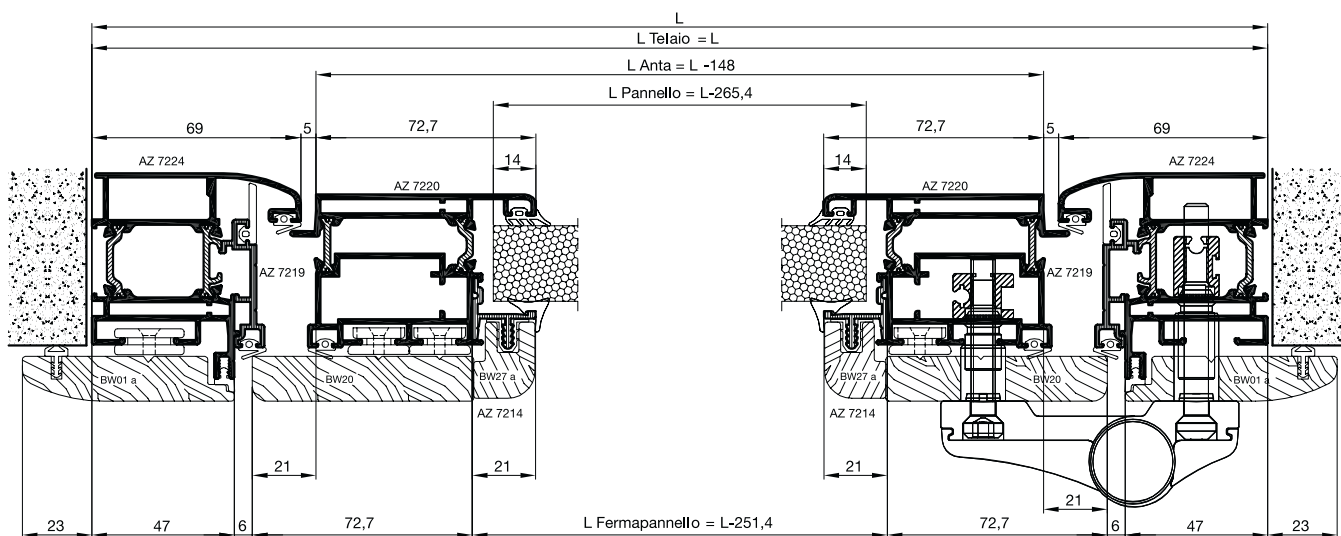
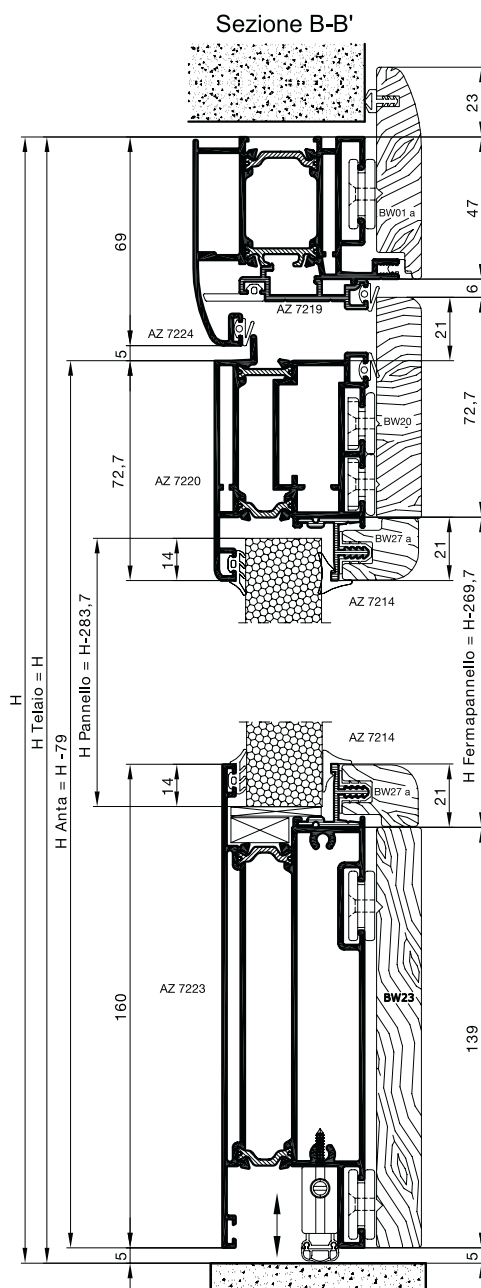

CALCOLO PESO PROFILI		TOTALE KG
Profili Orizz.	Kg/ml 7,3 x L	
Profili Vert.	Kg/ml 8,1 x H	
TOTALE		

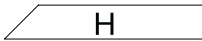
DISTINTA TAGLIO VETRI			
Posizione	l	h	Q.tà
	L - 265,4	H - 283,7	1

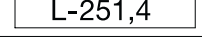
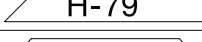
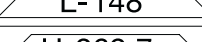
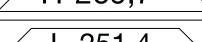

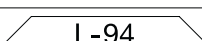
Sezione A-A'

DISTINTA TAGLIO PROFILI			
Nr. Pezzi	CODICI	DESCRIZIONE	TAGLIO
2	AZ 7224	MONTANTE TELAIO	
1	AZ 7224	TRAVERSO TELAIO SUP.	
1	AZ 7223	ZOCCOLO	
2	AZ 7220	MONTANTE ANTA	
1	AZ 7220	TRAVERSO ANTA SUP.	
2	AZ 7214	FERMAPANNELLO MONT.	
2	AZ 7214	FERMAPANNELLO TRAV.	
2	AZ 7219	BATTUTA RIPORTATA MONT.	
1	AZ 7219	BATTUTA RIPORTATA TRAV.	

DISTINTA TAGLIO LEGNI			
Nr. Pezzi	CODICI	DESCRIZIONE	TAGLIO
2	BW 01 a	TELAIO MONTANTE	
1	BW 01 a	TELAIO TRAVERSO SUP.	
1	BW 23	ZOCCOLO	
2	BW 20	ANTA MONTANTE	
1	BW 20	ANTA TRAVERSO SUP.	
2	BW 27 a	FERMAPANNELLO MONT.	
2	BW 27 a	FERMAPANNELLO TRAV.	

ACCESSORI		
ART.	DESCRIZIONE	N° P.zzi
Ra 2308	SQUADRETTA PER TELAIO	2
Ra 2006	SQUADRETTA PER TELAIO	2
Ra 2305	SQUADRETTA PER ANTA	2
Ra 2309	SQUADRETTA PER ANTA	2
Ra 2301	BLOCCHETTI DI UNIONE LEGNO ALLUMINIO	1 ogni 200mm
Ra 2302	BLOCCHETTI DI UNIONE LEGNO ALLUMINIO GRANDE	1 ogni 200mm
Ra 2328	KIT DI TENUTA SOTTOZOCZOLO tipo 2	1
Ra 2316	CERNIERA INTERASSE 70,5 mm	2
Ra 2319	BOCCOLE TELESCOPICHE PER TELAIO	2
Ra 2320	BOCCOLE TELESCOPICHE PER ANTA	2
Ra 2356	SERRATURA (entrata 30mm)	1
Ra 2330	CONTROPIASTRA CENTRALE	1
Ra 2331	CONTROPIASTRA SOPRA E SOTTO	2
Ra 2334	CILINDRO SAGOMATO	1
	MANIGLIA	1 coppia
Ra 2304	REGOLATORE A MURO PER TELAIO MAGGIORATO	6-10 <small>(secondo dimensioni)</small>

GUARNIZIONI			
	ART.	DESCRIZIONE	N° P.zzi
	Rg 345	G. INTERNA VETRO	2L + 2H
	Rg 311	G. ESTERNA VETRO	2L + 2H
	Rg 337	G. BATTUTA RIPORTATA	1L + 2H
	Rg 401	G. DI BATTUTA PORTE	3L + 6H
	Rg 344	G. A MURO	1L + 2H
	Rg 334	G. DI FISSAGGIO FERMAVETRO	2L + 2H
	Rg 336	G. ISOLAMENTO ALLUMINIO LEGNO	1L + 2H

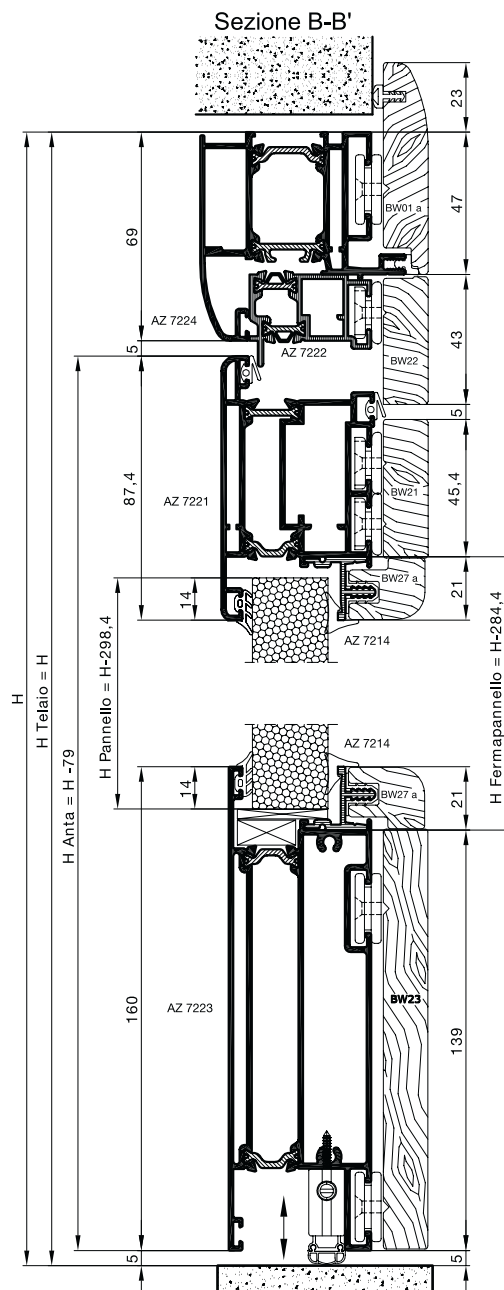
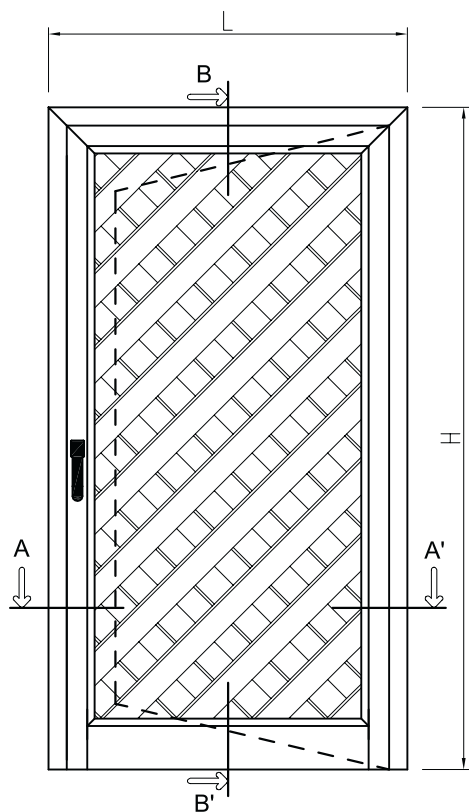

CALCOLO PESO PROFILI		TOTALE KG
Profili Orizz.	Kg/ml 8 x L	
Profili Vert.	Kg/ml 9,2 x H	
TOTALE		

DISTINTA TAGLIO PANNELLO			
Posizione	l	h	Q.tà
	L - 294,8	H - 298,4	1

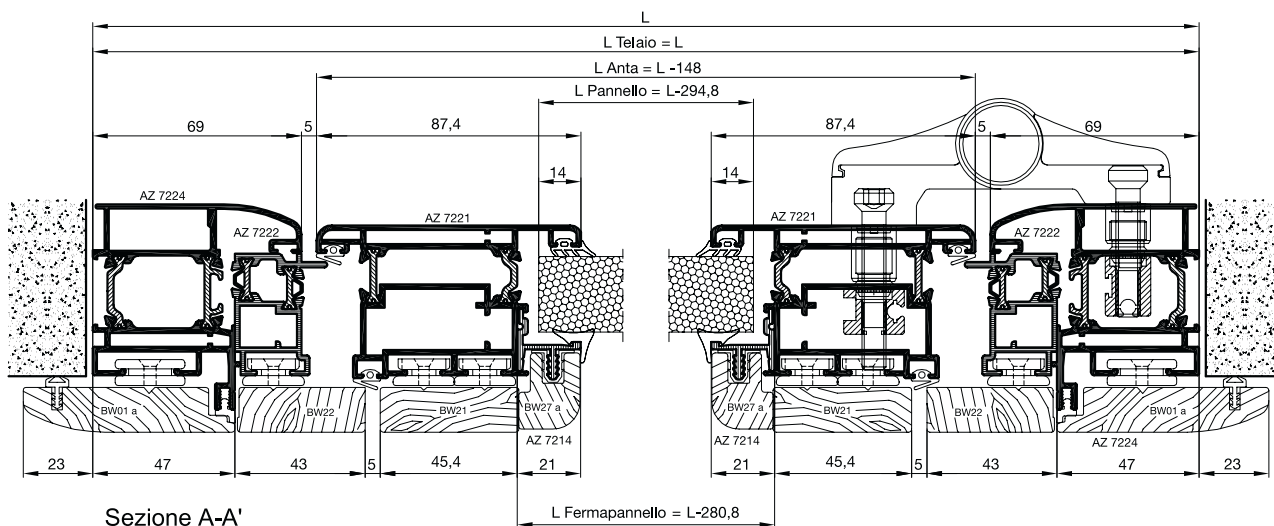

DISTINTA TAGLIO PROFILI

Nr. Pezzi	CODICI	DESCRIZIONE	TAGLIO
2	AZ 7224	MONTANTE TELAIO	
1	AZ 7224	TRAVERSO TELAIO SUP.	
1	AZ 7223	ZOCCOLO	
2	AZ 7221	MONTANTE ANTA	
1	AZ 7221	TRAVERSO ANTA SUP.	
2	AZ 7214	FERMAPANNELLO MONT.	
2	AZ 7214	FERMAPANNELLO TRAV.	
2	AZ 7222	INVERSIONE DI BATTUTA MONT.	
1	AZ 7222	INVERSIONE DI BATTUTA TRAV.	

DISTINTA TAGLIO LEGNI

Nr. Pezzi	CODICI	DESCRIZIONE	TAGLIO
2	BW 01 a	TELAIO MONTANTE	
1	BW 01 a	TELAIO TRAVERSO SUP.	
1	BW 23	ZOCCOLO	
2	BW 21	ANTA MONTANTE	
1	BW 21	ANTA TRAVERSO SUP.	
2	BW 22	INVERSIONE DI BATTUTA MONT.	
1	BW 22	INVERSIONE DI BATTUTA TRAV.	
2	BW 27 a	FERMAPANNELLO MONT.	
2	BW 27 a	FERMAPANNELLO TRAV.	

ACCESSORI

ART.	DESCRIZIONE	N° P.zzi
Ra 2308	SQUADRETTA PER TELAIO	2
Ra 2006	SQUADRETTA PER TELAIO	2
Ra 2305	SQUADRETTA PER ANTA	2
Ra 2309	SQUADRETTA PER ANTA	2
Ra 2301	BLOCCHETTI DI UNIONE LEGNO ALLUMINIO	1 ogni 200mm
Ra 2302	BLOCCHETTI DI UNIONE LEGNO ALLUMINIO GRANDE	1 ogni 200mm
Ra 2328	KIT DI TENUTA SOTTOZOCZOLO tipo 2	1
Ra 2314	CERNIERA INTERASSE 84 mm	2
Ra 2318	BOCCOLE TELESCOPICHE PER TELAIO	2
Ra 2320	BOCCOLE TELESCOPICHE PER ANTA	2
Ra 2356	SERRATURA (entrata 30mm)	1
Ra 2332	CONTROPIASTRA CENTRALE	1
Ra 2333	CONTROPIASTRA SOPRA E SOTTO	2
Ra 2334	CILINDRO SAGOMATO	1
	MANIGLIA	1 coppia
Ra 2304	REGOLATORE A MURO PER TELAIO MAGGIORATO	6-10 (secondo dimensioni)

GUARNIZIONI

	ART.	DESCRIZIONE	N° P.zzi
	Rg 345	G. INTERNA VETRO	2L + 2H
	Rg 311	G. ESTERNA VETRO	2L + 2H
	Rg 401	G. DI BATTUTA PORTE	2L + 4H
	Rg 344	G. A MURO	1L + 2H
	Rg 334	G. DI FISSAGGIO FERMAVETRO	2L + 2H
	Rg 336	G. ISOLAMENTO ALLUMINIO LEGNO	1L + 2H

E' ESCLUSA LA FERRAMENTA DI MOVIMENTAZIONE

PORTONCINO A DUE ANTE DOPPIA BATTUTA
- apertura interna

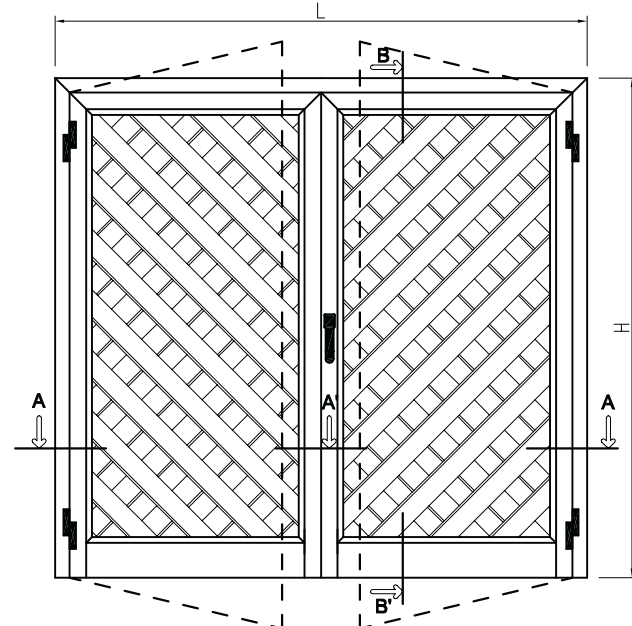
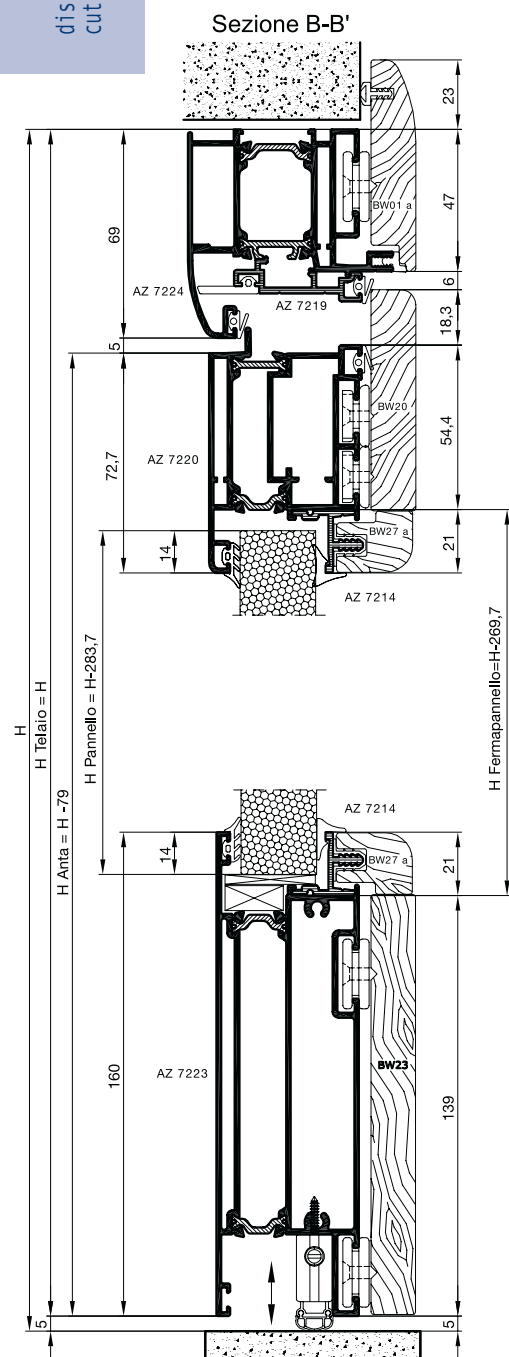

CALCOLO PESO PROFILI			TOTALE KG
Profili Orizz.	Kg/ml	7,3 x L	
Profili Vert.	Kg/ml	12,3 x H	
TOTALE			

DISTINTA TAGLIO PANNELLO			
Posizione	l	h	Q.tà
	L-L/2- 201,2	H - 283,7	2

ACCESSORI		
ART.	DESCRIZIONE	N° P.zzi
Ra 2308	SQUADRETTA PER TELAIIO	2
Ra 2006	SQUADRETTA PER TELAIIO	2
Ra 2305	SQUADRETTA PER ANTA	4
Ra 2309	SQUADRETTA PER ANTA	4
Ra 2301	BLOCCHETTI DI UNIONE LEGNO ALLUMINIO	1 ogni 200mm
Ra 2302	BLOCCHETTI DI UNIONE LEGNO ALLUMINIO GRANDE	1 ogni 200mm
Ra 2328	KIT DI TENUTA SOTTOZOCOLO tipo 2	1
Ra 2316	CERNIERA INTERASSE 70,5 mm	4
Ra 2319	BOCCOLE TELESCOPICHE PER TELAIIO	4
Ra 2320	BOCCOLE TELESCOPICHE PER ANTA	4
Ra 2356	SERRATURA (entrata 30mm)	1
Ra 2330	CONTROPIASTRA CENTRALE	1
Ra 2331	CONTROPIASTRA SOPRA E SOTTO	2
Ra 2334	CILINDRO SAGOMATO	1
Ra 2322	CATENACCIO PESOS	2
	MANIGLIA	1 coppia
Ra 2304	REGOLATORE A MURO PER TELAIIO MAGGIORATO	9-12 (secondo dimensioni)

E' ESCLUSA LA FERRAMENTA DI MOVIMENTAZIONE

DISTINTA TAGLIO PROFILI			
Nr. Pezzi	CODICI	DESCRIZIONE	TAGLIO
2	AZ 7224	MONTANTE TELAIIO	H
1	AZ 7224	TRAVERSO TELAIIO	L
3	AZ 7220	MONTANTE ANTA	H-70,5
1	AZ 7221	MONTANTE ANTA	H-64,3
2	AZ 7220	TRAVERSO ANTA	L-L/2-66,8
4	AZ 7214	FERMAPANNELLO MONT.	H-269,7
4	AZ 7214	FERMAPANNELLO TRAV.	L-L/2-187,2
2	AZ 7219	BATTUTA RIPORTATA MONT.	H-47
1	AZ 7219	BATTUTA RIPORTATA TRAV.	L-94
2	AZ 7223	ZOCCOLO	L-L/2-187,3

DISTINTA TAGLIO LEGNI			
Nr. Pezzi	CODICI	DESCRIZIONE	TAGLIO
2	BW 01 a	TELAIO MONT.	H+ 23
1	BW 01 a	TELAIO TRAV. SUP.	L+ 46
1	BW 21	ANTA MONT. AZ 7221	H-85,3
3	BW 20	ANTA MONT. AZ 7220	H-58
1	BW 20	ANTA TRAV. AZ 7220	L-L/2-41,8
1	BW 20	ANTA TRAV. AZ 7221	L-L/2-69,2
4	BW 27 a	FERMAPANNELLO MONT.	H-269,7
4	BW 27 a	FERMAPANNELLO TRAV.	L-L/2-187,2
2	BW 23	ZOCCOLO	L-L/2-187,2

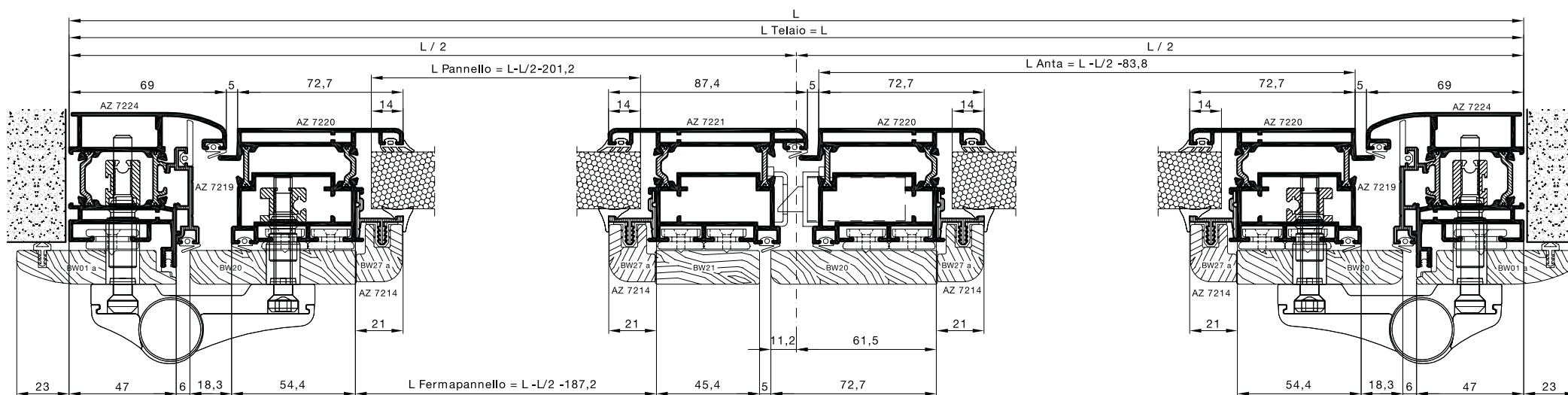

Sezione A-A'

GUARNIZIONI			
	ART.	DESCRIZIONE	N° P.zzi
	Rg 345	G. INTERNA VETRO	2L + 4H
	Rg 311	G. ESTERNA VETRO	2L + 4H
	Rg 337	G. BATTUTA RIPORTATA	1L + 2H
	Rg 401	G. DI BATTUTA PORTE	3L + 9H
	Rg 344	G. A MURO	1L + 2H
	Rg 334	G. DI FISSAGGIO FERMAVETRO	2L + 4H
	Rg 336	G. ISOLAMENTO ALLUMINIO LEGNO	1L + 2H

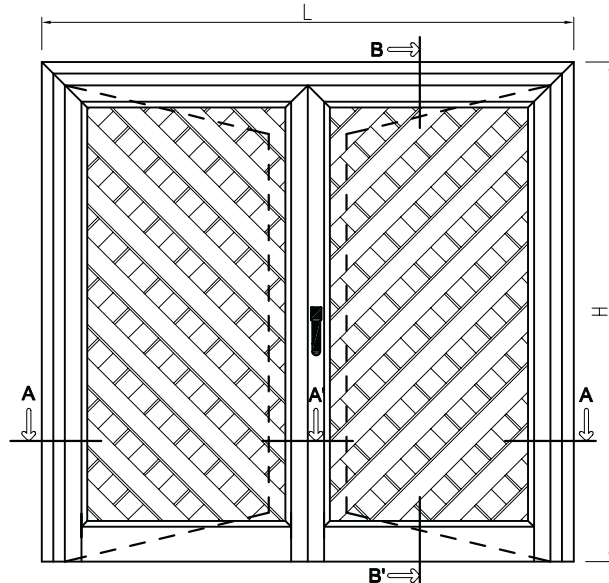
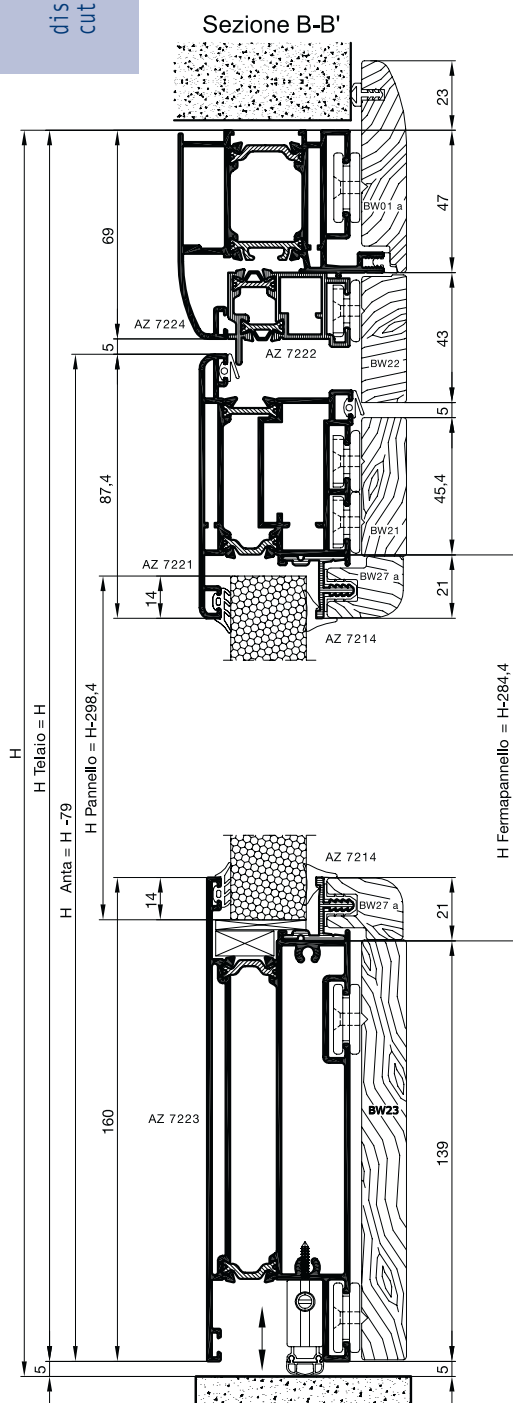

CALCOLO PESO PROFILI		TOTALE
Profili Orizz.	Kg/ml $7,9 \times L$	
Profili Vert.	Kg/ml $13,4 \times H$	
TOTALE		

DISTINTA TAGLIO PANNELLO			
Posizione	l	h	Q.tà
	L-L/2- 215,9	H - 298,4	2

ACCESSORI		
ART.	DESCRIZIONE	N° P.zzi
Ra 2308	SQUADRETTA PER TELAIO	2
Ra 2006	SQUADRETTA PER TELAIO	2
Ra 2305	SQUADRETTA PER ANTA	4
Ra 2309	SQUADRETTA PER ANTA	4
Ra 2301	BLOCCHETTI DI UNIONE LEGNO ALLUMINIO	1 ogni 200mm
Ra 2302	BLOCCHETTI DI UNIONE LEGNO ALLUMINIO GRANDE	1 ogni 200mm
Ra 2328	KIT DI TENUTA SOTTOZOCCOLO tipo 2	1
Ra 2314	CERNIERA INTERASSE 84 mm	4
Ra 2318	BOCCOLE TELESCOPICHE PER TELAIO	4
Ra 2320	BOCCOLE TELESCOPICHE PER ANTA	4
Ra 2356	SERRATURA (entrata 30mm)	1
Ra 2332	CONTROPIASTRA CENTRALE	1
Ra 2333	CONTROPIASTRA SOPRA E SOTTO	2
Ra 2334	CILINDRO SAGOMATO	1
Ra 2323	CATENACCIO TOTEM	2
Ra 2324	INCONTRI PER CATENACCIO TOTEM	2
	MANIGLIA	1 coppia
Ra 2304	REGOLATORE A MURO PER TELAIO MAGGIORATO	9-12 (secondo dimensioni)

E' ESCLUSA LA FERRAMENTA DI MOVIMENTAZIONE

DISTINTA TAGLIO PROFILI			
Nr. Pezzi	CODICI	DESCRIZIONE	TAGLIO
2	AZ 7224	MONTANTE TELAIO	H
1	AZ 7224	TRAVERSO TELAIO	L
3	AZ 7221	MONTANTE ANTA	H-79
1	AZ 7220	MONTANTE ANTA	H-85,2
2	AZ 7221	TRAVERSO ANTA	L-L/2-69,2
4	AZ 7214	FERMAPANNELLO MONT.	H-284,4
4	AZ 7214	FERMAPANNELLO TRAV.	L-L/2-201,9
2	AZ 7222	INVERSIONE DI BATTUTA MONT.	H-47
1	AZ 7222	INVERSIONE DI BATTUTA TRAV.	L-94
2	AZ 7223	ZOCCOLO	L-L/2-201,9

DISTINTA TAGLIO LEGNI			
Nr. Pezzi	CODICI	DESCRIZIONE	TAGLIO
2	BW 01 a	TELAIO MONT.	H+ 23
1	BW 01 a	TELAIO TRAV. SUP.	L+ 46
3	BW 21	ANTA MONT. AZ 7221	H-100
1	BW 20	ANTA MONT. AZ 7220	H-72,7
2	BW 21	ANTA TRAV.	L-L/2-111,2
1	BW 22	INVERSIONE DI BATTUTA TRAV.	L-94
2	BW 22	INVERSIONE DI BATTUTA MONT.	H-47
4	BW 27 a	FERMAPANNELLO MONT.	H-284,4
4	BW 27 a	FERMAPANNELLO TRAV.	L-L/2-201,9
2	BW 23	ZOCCOLO	L-L/2-201,9

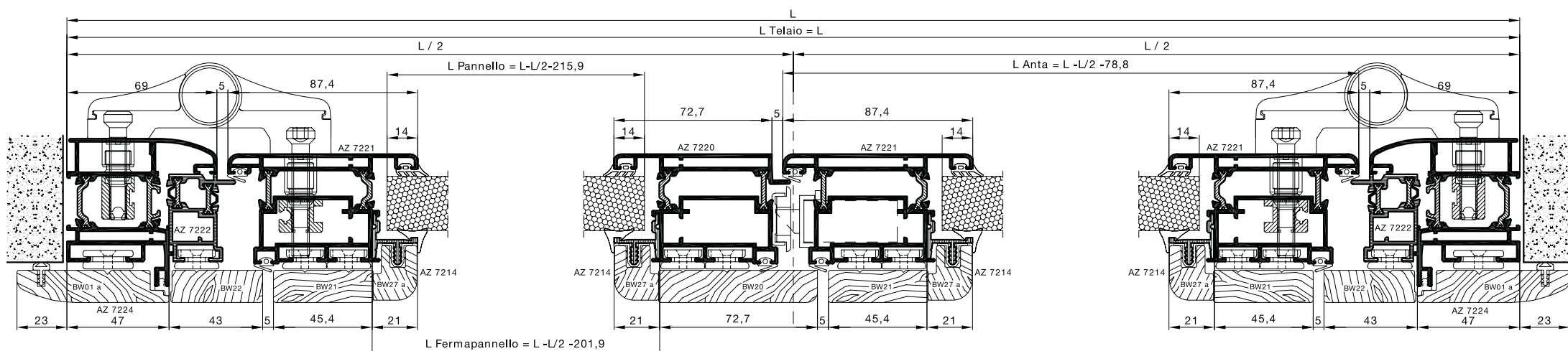

Sezione A-A'

GUARNIZIONI			
	ART.	DESCRIZIONE	N° P.zzi
▶	Rg 345	G. INTERNA VETRO	2L + 4H
◀	Rg 311	G. ESTERNA VETRO	2L + 4H
◁	Rg 401	G. DI BATTUTA PORTE	2L + 7H
⊥	Rg 344	G. A MURO	1L + 2H
U	Rg 334	G. DI FISSAGGIO FERMAVETRO	2L + 4H
⊥	Rg 336	G. ISOLAMENTO ALLUMINIO LEGNO	1L + 2H